

MMG35DF4

Diesel Generator Parts Manual

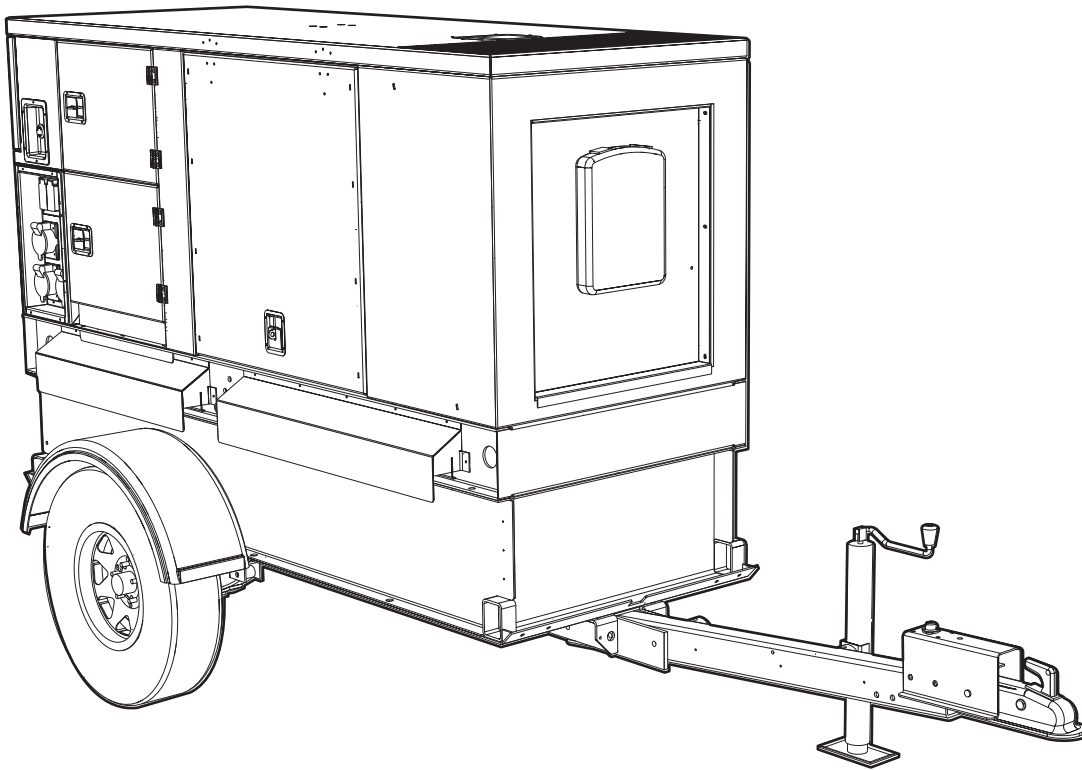

02670

MODEL NUMBER: _____

SERIAL NUMBER: _____

DATE PURCHASED: _____

SAVE THIS MANUAL FOR FUTURE REFERENCE

 **WARNING**

CANCER AND REPRODUCTIVE HARM

www.P65Warnings.ca.gov.

(000393a)

 **WARNING**

Breathing diesel engine exhaust exposes you to chemicals known to the State of California to cause cancer and birth defects or other reproductive harm.

- Always start and operate the engine in a well-ventilated area.
- If in an enclosed area, vent the exhaust to the outside.
- Do not modify or tamper with the exhaust system.
- Do not idle the engine except as necessary.

For more information go to

www.P65Warnings.ca.gov/diesel.

(000394)

Introduction

This parts manual was prepared based on the information available at the time of publication and is subject to change without notice. Generac Mobile Products reserves the right to change parts at any time. To check whether a revised parts manual is available, contact Generac Mobile Products.

DO NOT MODIFY or use this equipment for any application other than which it was designed for. To keep your equipment fully operational, it is suggested you maintain a stock of commonly used maintenance or service parts. A recommended spare parts list can be found in the back of this manual. To order service parts, please go to www.generacmobileproducts.com or call Generac Mobile Products.



WARNING

Consult Manual. Read and understand manual completely before using product. Failure to completely understand manual and product could result in death or serious injury. (000100a)

WARNING

Environmental Hazard. Always recycle batteries at an official recycling center in accordance with all local laws and regulations. Failure to do so could result in environmental damage, death or serious injury. (000228)

GENERAC MOBILE PRODUCTS LLC
215 Power Drive • Berlin, WI 54923 U.S.A.
Phone: 920-361-4442
FAX: 920-361-4416
Toll Free: 1-800-926-9768
www.generacmobileproducts.com

For technical or parts **QUESTIONS**, contact Generac Mobile Products Technical Service at 1-800-926-9768.

Engine Make: _____
Engine Serial Number: _____
Engine Model Number: _____

This Page Intentionally Left Blank

Table of Contents

Introduction	iii
General Information	1
Unit Decals - Exterior	2
Unit Decals - Left Side Interior	4
Unit Decals - Right Side Interior	6
Unit Decals - Electrical Boxes	8
Enclosure Panels	10
Doors, Roof, and Front Enclosure To Unit	12
Left Side Door Assembly	14
Right Side Door Assembly	16
Electrical Boxes To Unit	18
Front Enclosure Assembly	20
AC Box Assembly (1 of 2)	22
AC Box Assembly (2 of 2)	24
Lug Box Assembly	26
Bottom Rear Box Assembly	28
Receptacle Panel Assembly	30
Control Box Assembly	32
Control Panel Assembly	34
Control Door Assembly	36
Lift Structure To Skid Assembly	38
Cooling System Assembly	40
Cooling System Hoses	42
Engine and Generator To Skid Assembly	44
Engine Assembly	46
Generator Assembly	48
Skid Assembly	50
Fuel Tank Assembly	52
Trailer Assembly - Single Axle	54
Trailer Assembly - Tandem Axle	56
Trailer Brake Lines - Single Axle	58
Trailer Brake Lines - Tandem Axle	60
Trailer Hitch Options	62
Recommended Spare Parts - Engine and Service Kits	64
Recommended Spare Parts - Electrical and Trailer	66

This Page Intentionally Left Blank

General Information

Products supplied may vary from the illustrations in this parts manual. Parts not shown in the illustration are indicated by a double dash (--)

When ordering replacement parts, be prepared to provide the model number, serial number, part number, purchase order number (if required), customer ID, shipping address and desired shipping method.

Illustrated below are the unit identification tag and the VIN tag. These tags contain the model number, serial number, vehicle identification number (VIN) and tire loading information.

UNIT ID Tag

Manufactured by Magnum Power Products, LLC.,
a subsidiary of Generac Power Systems, Inc.
(800) 361-4442 (800) 928-9788

Country of Origin	Model	Serial Number
Manufacturing Code	Weight (lbs/kg)	RPM/Frequency
1 ph. 1.0PF	3 ph. 8PF	3 ph. 1.0PF
KW		
KVA		
V		
A		
		Rating
		Wts. Class

FIA 1973/74 Agreement
 1973/74 Agreement
 1973/74 Agreement
 1973/74 Agreement
 Form 975232B

Located behind breaker door underneath breakers

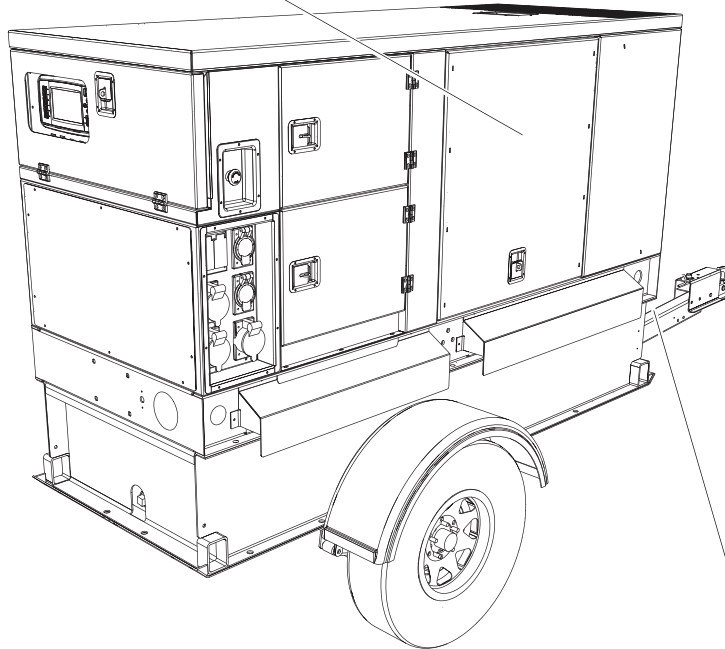

VIN Tag

MANUFACTURED BY/FABRIQUE PAR: Magnum Power Products LLC		DATE: 00/0000
GVWR/PNEU: 000KG (0000LBS)	COLD INF. PRESS./	
GAWR / PNEU	TIRE / PNEU	RIM / JANTE
GONF A FROID - KPA(Psi)/PCJ SGL / DUAL		
VIN: N1LV 000000000000000000		MODEL: XXX000
		TYPE: TRAILER

TIRE AND LOADING INFORMATION
RENSEIGNEMENTS SUR LES PNEUS ET LE CHARGEMENT

The weight of cargo should never exceed 0000KG (0000LBS)
Le poids du chargement ne doit jamais dépasser 0000KG (0000LBS)

SEE OWNER'S MANUAL FOR ADDITIONAL INFORMATION
VOIR LE MANUEL DE L'USAGER POUR PLUS DE RENSEIGNEMENTS

Located on opposite side of trailer

01028

UNIT DECALS - EXTERIOR

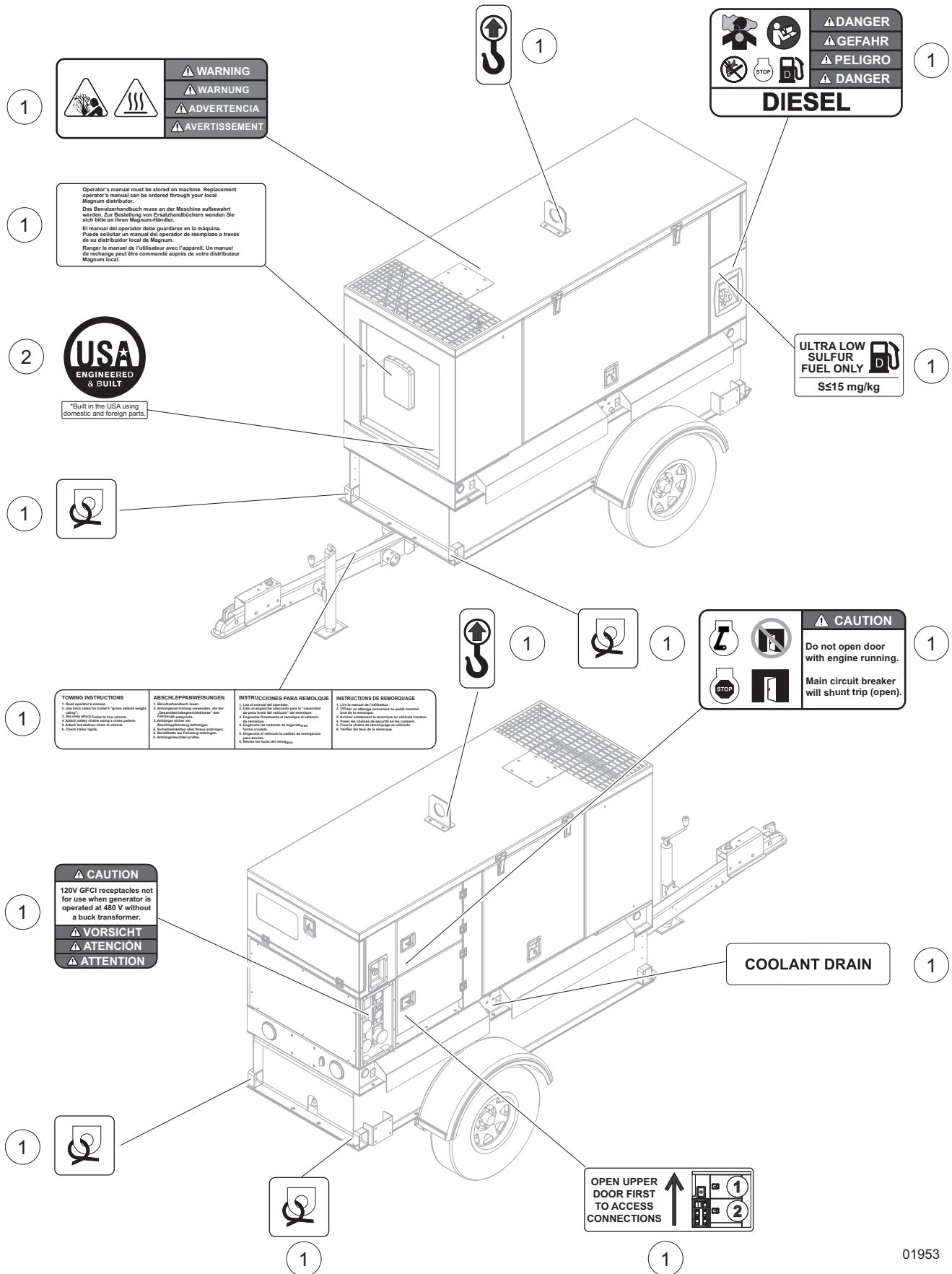

UNIT DECALS - ELECTRICAL BOXES

Item	Part No.	Qty	Description	Notes
1	37467	1	Decal, safety - small F4	
2	50909	1	Decal, USA engineered & built	

UNIT DECALS - LEFT SIDE INTERIOR

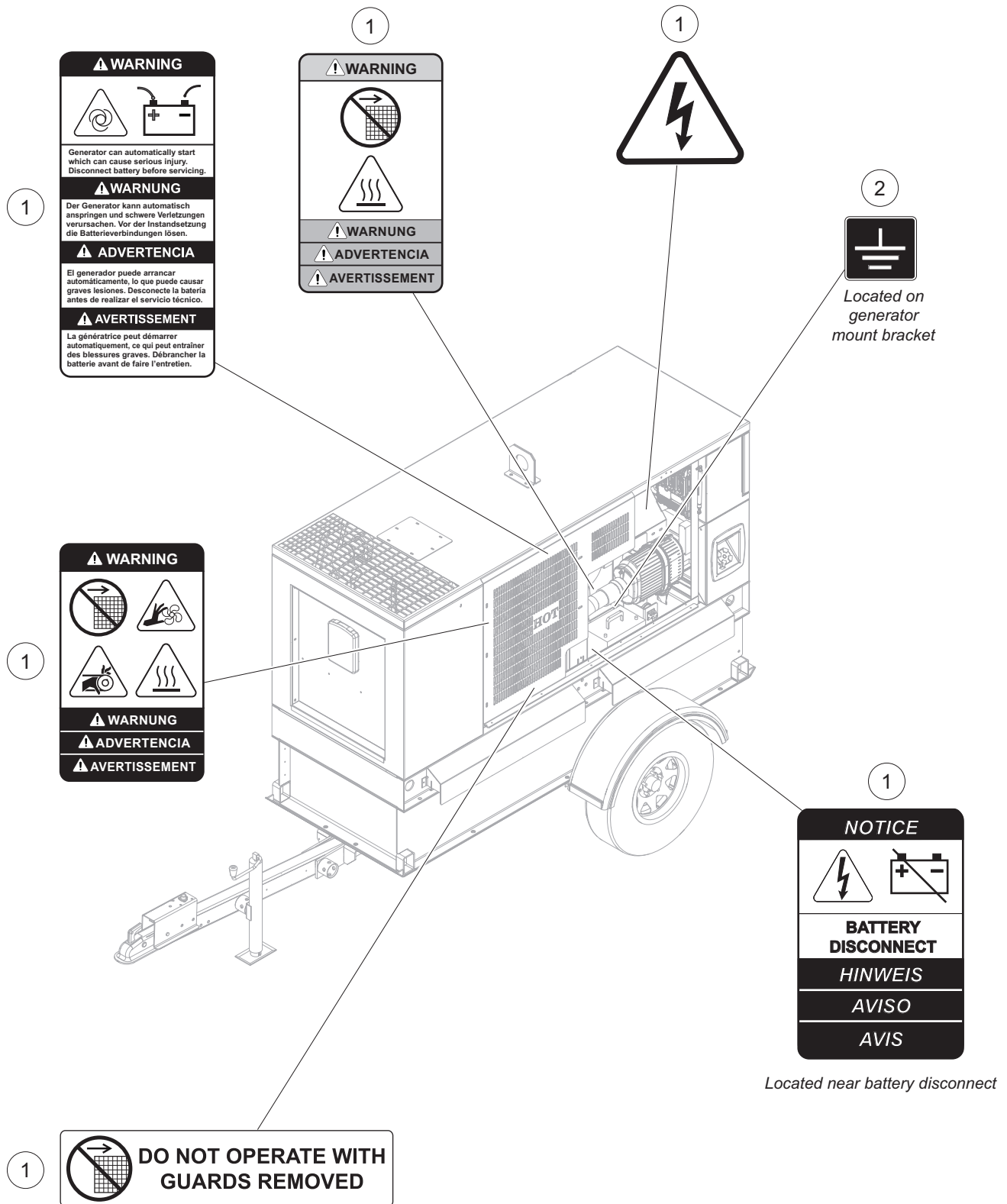

02656

UNIT DECALS - LEFT SIDE INTERIOR

Item	Part No.	Qty	Description	Notes
1	37695	1	Decal, safety - small F4	
2	12142	1	Decal, ground	

UNIT DECALS - RIGHT SIDE INTERIOR

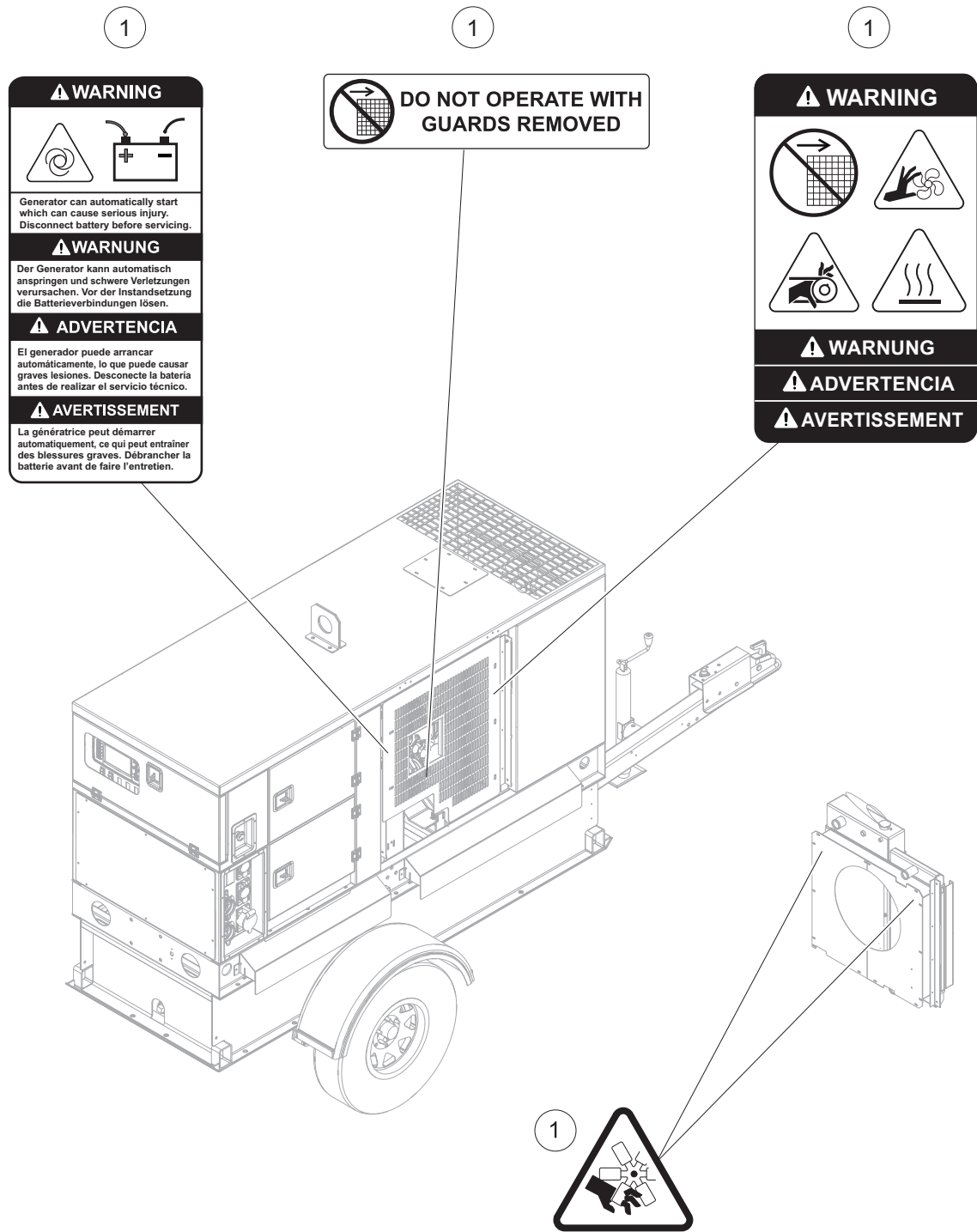

01955

UNIT DECALS - RIGHT SIDE INTERIOR

Item	Part No.	Qty	Description	Notes
1	37695	1	Decal, safety - small F4	

UNIT DECALS - ELECTRICAL BOXES

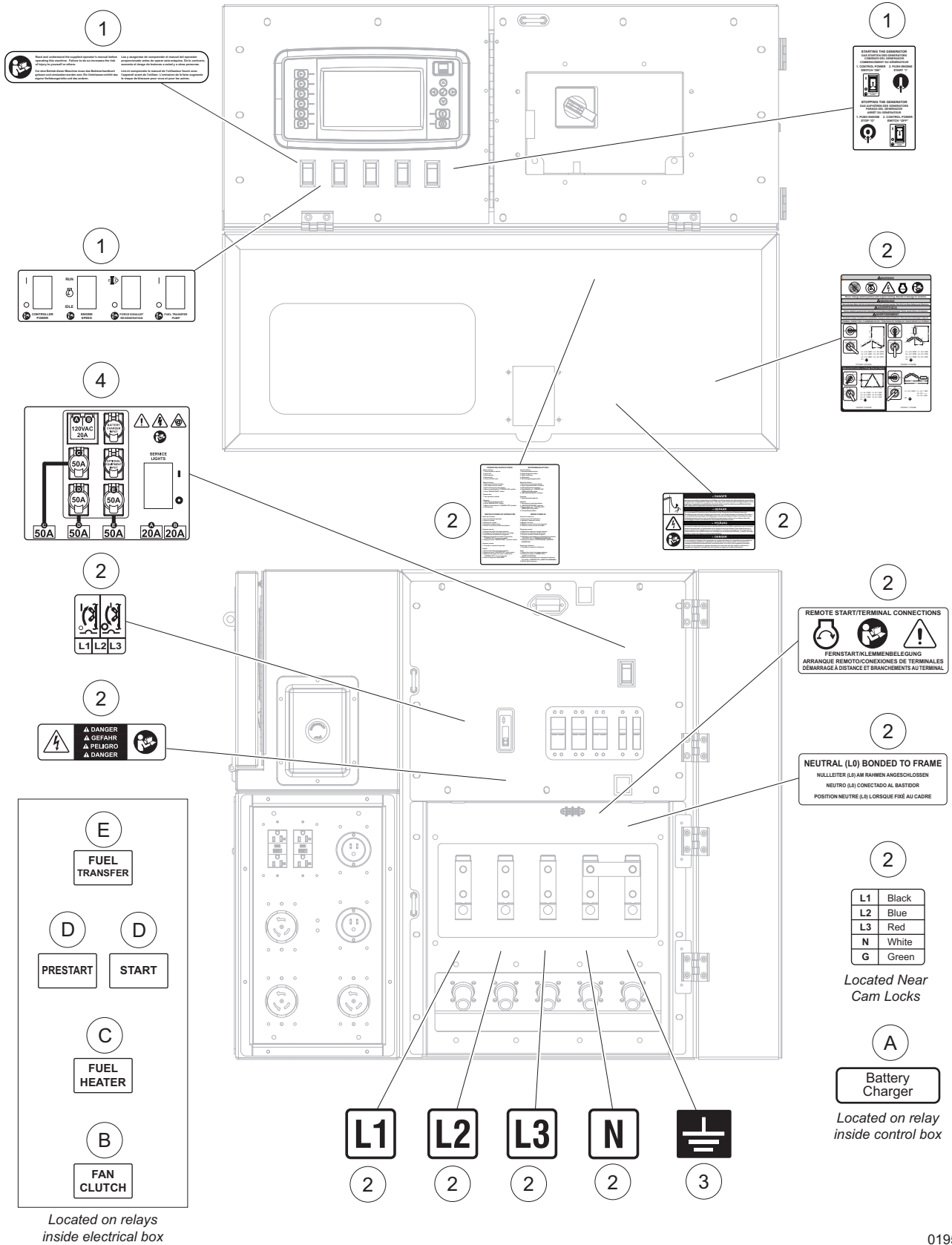

UNIT DECALS - ELECTRICAL BOXES

Item	Part No.	Qty	Description	Notes
1	52972	1	Decal, safety - small F4 control 5-position	
2	37695	1	Decal, safety - small F4	
3	12142	1	Decal, ground	
4	37820	1	Decal, breaker - small F4	

ENCLOSURE PANELS

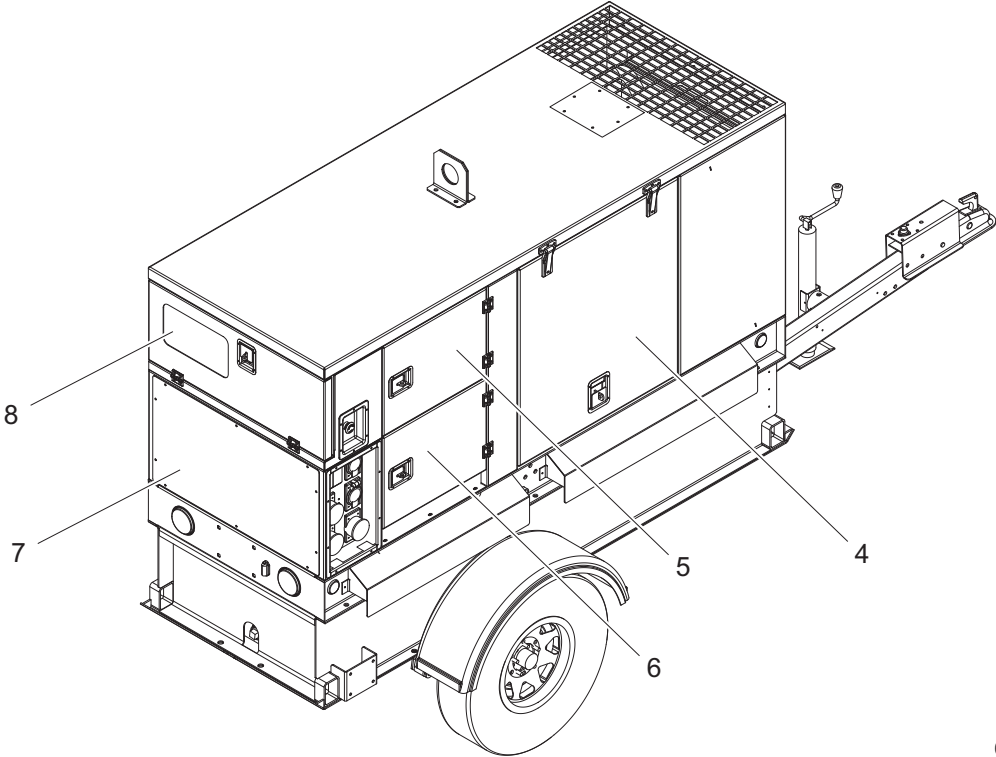
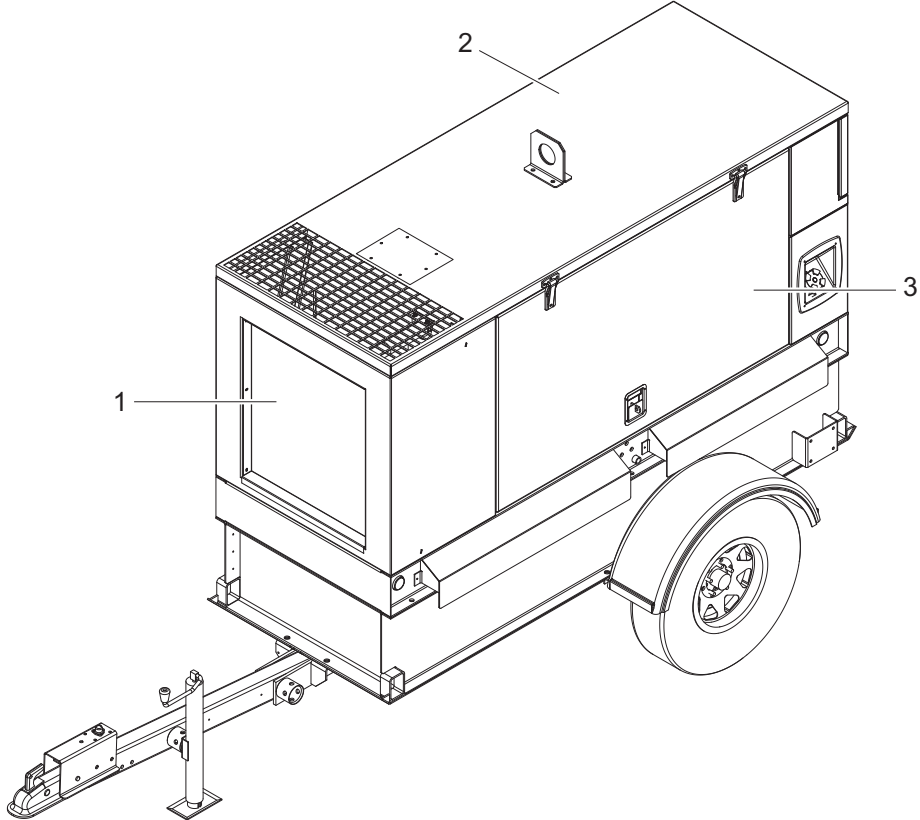

01085

ENCLOSURE PANELS

Item	Part No.	Qty	Description	Notes
1	10000036026	1	Front Enclosure Assembly	Page 20
2	10000036266	1	Roof Assembly	Page 12
3	10000036235	1	Left Side Door Assembly	Page 14
4	10000036081	1	Right Side Door Assembly	Page 16
5	10000036046	1	Breaker Door Assembly	Page 22
6	10000036047	1	Lug/Cam Door Assembly	Page 22
7	10000036067	1	Bottom Rear Box Assembly	Page 28
8	10000036048	1	Control Door Assembly	Page 36

DOORS, ROOF, AND FRONT ENCLOSURE TO UNIT

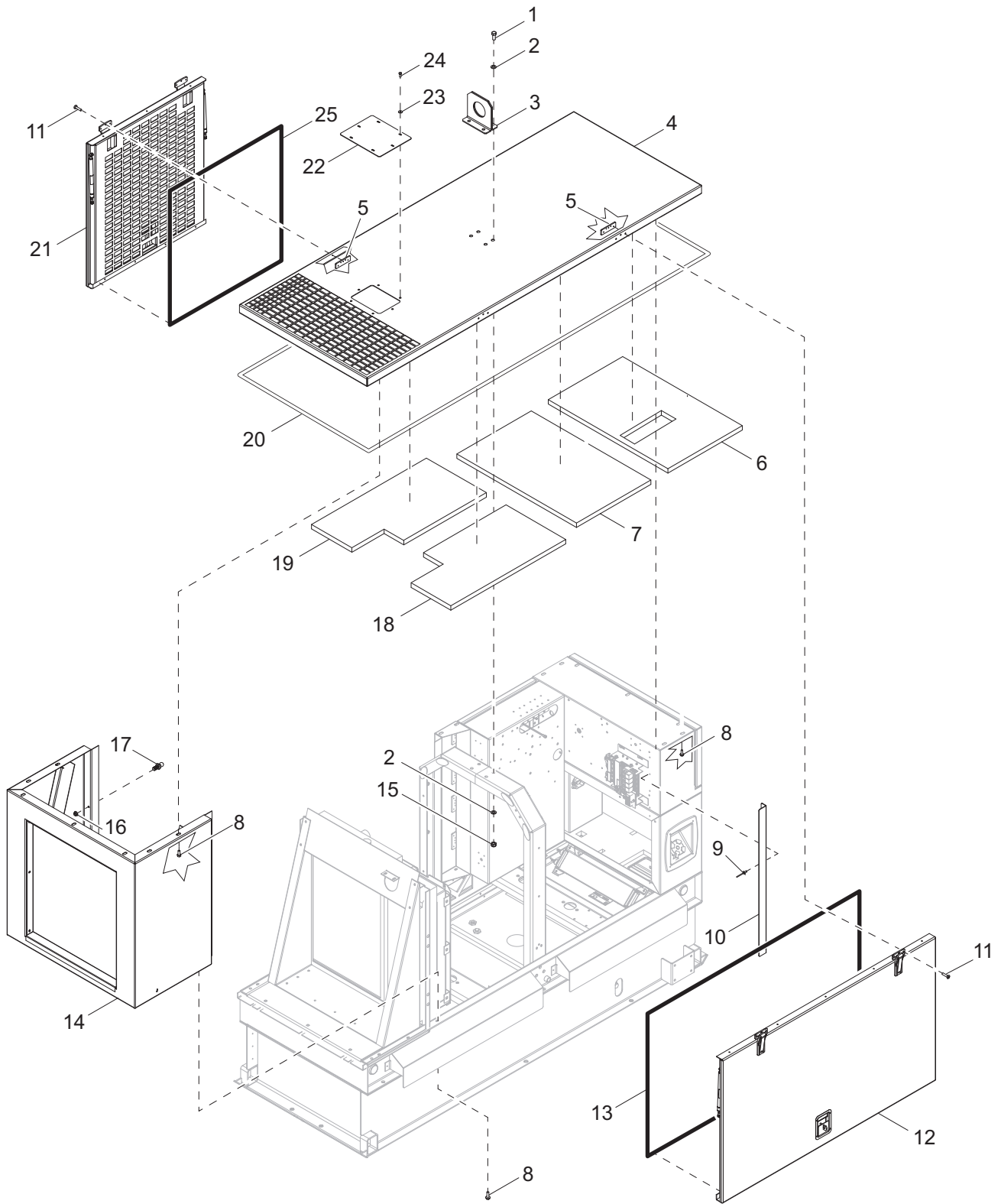

01912

DOORS, ROOF, AND FRONT ENCLOSURE TO UNIT

Item	Part No.	Qty	Description	Notes
1	60388	4	Screw, .500-13 x 1.50 standard hex, G5	
2	60309	8	Washer, .500 flat 1.060/.090	
3	37115B	1	Weldment, lifting eye	
4	35728W	1	Panel, roof	
5	37136ZC	4	Plate, hinge back - threaded	
6	10000035998	1	Foam, roof - rear	
7	10000036056	1	Foam, roof - middle rear	
8	60616	25	Screw, .312-18 x .750 serrated flange hex, G5	
9	60268	6	Rivet, .188 diameter x .126 to .250 grip, SS	
10	37544W	1	Flange, door	
11	35290	12	Screw, 10-24 x 1.0 flat Phillips, SS	
12	10000036235	1	Assembly, left side door	
13	50187	10.83 ft	Seal, door - D-shaped (.750)	
14	10000036026	1	Assembly, front enclosure	
15	62221	4	Nut, .500-13 nylock, G5	
16	60095	4	Nut, .312-18 serrated flange	
17	35293	4	Stud, ball - 10 mm, .312-18	
18	10000036009	1	Foam, roof - front left	
19	10000036072	1	Foam, roof - front right	
20	50197	16 ft	Weatherstripping - .06 x 1.0	
21	10000036081	1	Assembly, right side door	
22	37214W	1	Panel, radiator access thru roof	
23	60452	6	Washer, .313 flat 1.125/1.0 bonded rubber, SS	
24	60684	6	Screw, .250-20 x .875 standard hex, SS	
25	50187	8.5 ft	Seal, door - D-shaped (.750)	

LEFT SIDE DOOR ASSEMBLY

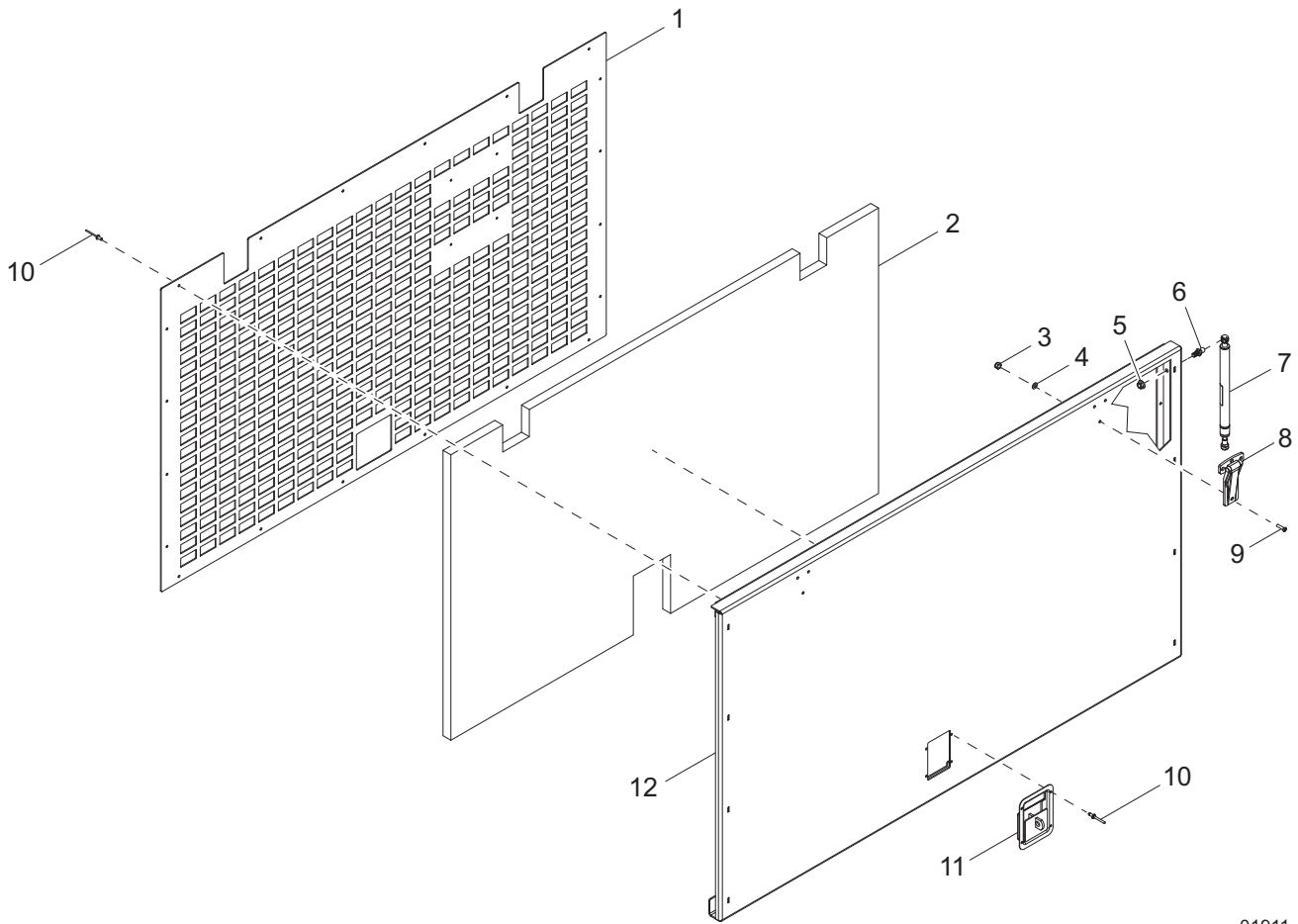
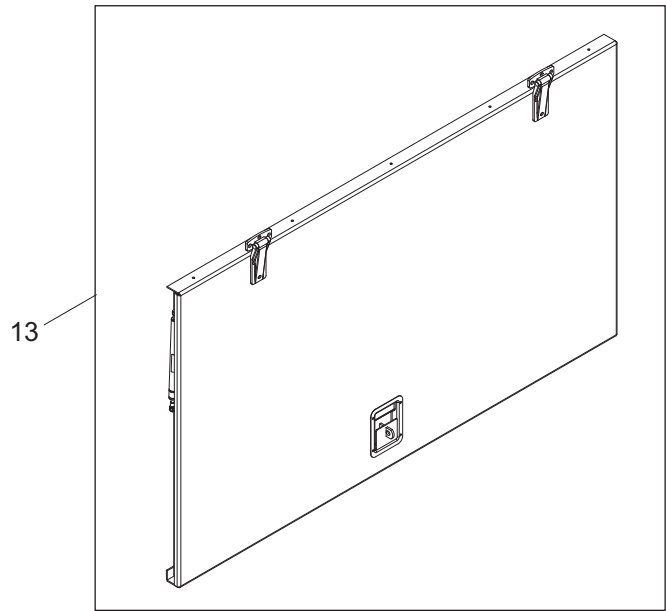

01911

LEFT SIDE DOOR ASSEMBLY

Item	Part No.	Qty	Description	Notes
1	37847W	1	Panel, inner	
2	10000036069	1	Foam, door	
3	60457	6	Nut, 10-24 nylock, G2	
4	60237	6	Washer, #10 flat .495/.036	
5	60095	2	Nut, .312-18 serrated flange	
6	35293	2	Stud, ball - 10 mm, .312-18	
7	37821	2	Shock, gas - 150 lb, 7 in. stroke	
8	35136	2	Hinge, flush mount	
9	35290	6	Screw, 10-24 x 1.0 flat head Phillips, SS	
10	60268	24	Rivet, .188 diameter x .126 to .250 grip, SS	
11	37145B	1	Latch, paddle - mini, black	
12	37845W	1	Weldment, large door	
13	10000036235	1	Assembly, left side door	Items 1-12

RIGHT SIDE DOOR ASSEMBLY

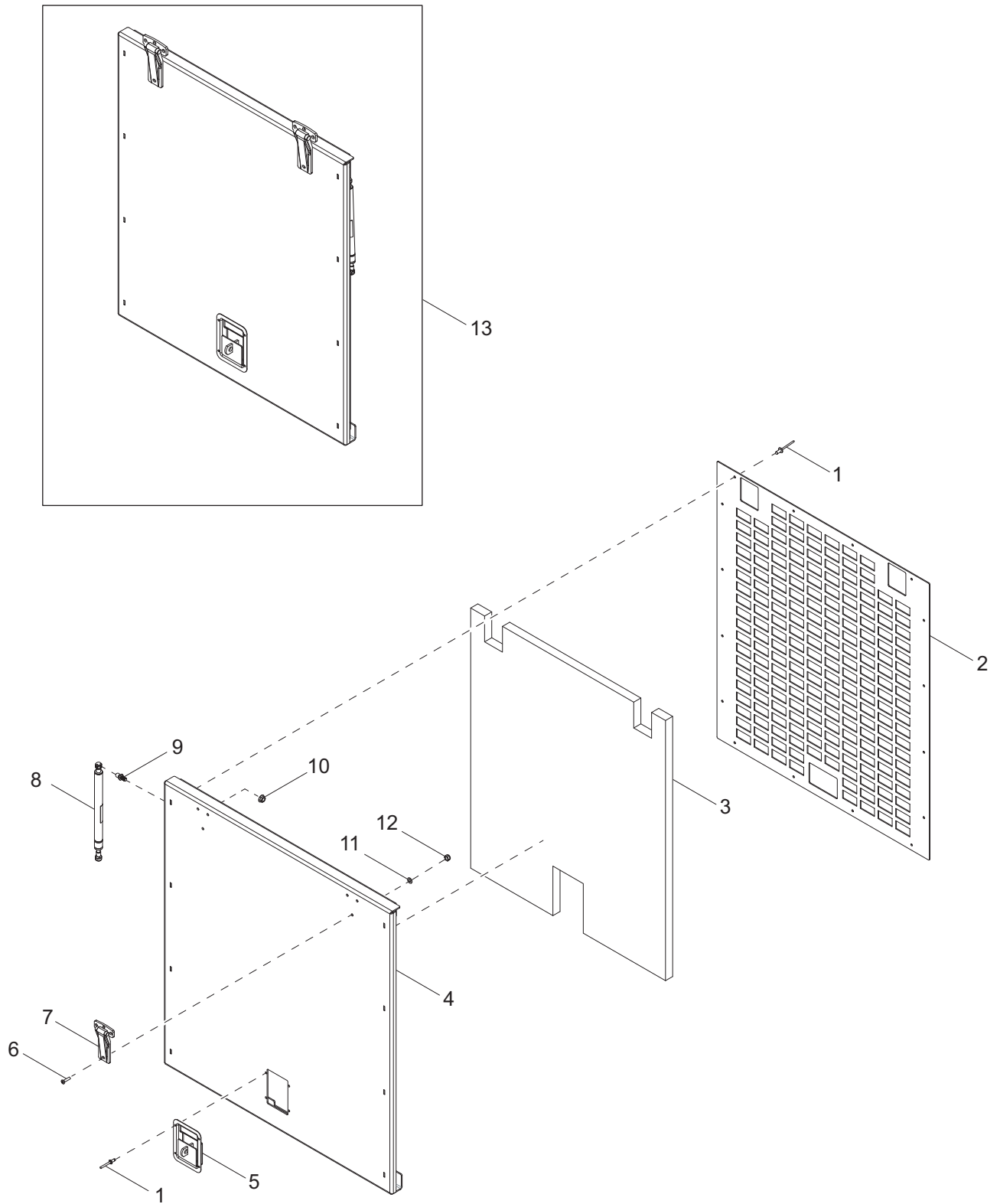

02065

RIGHT SIDE DOOR ASSEMBLY

Item	Part No.	Qty	Description	Notes
1	60268	20	Rivet, .188 diameter x .126 to .250 grip, SS	
2	37854W	1	Panel, inner	
3	37046SRV	1	Foam, door	
4	37852W	1	Weldment, small door	
5	37145B	1	Latch, paddle - mini, black	
6	35290	6	Screw, 10-24 x 1.0 flat head Phillips, SS	
7	35136	2	Hinge, flush mount	
8	37533	2	Shock, gas - 80 lbs, 6.75 in. stroke	
9	35293	2	Stud, ball - 10 mm, .313-18	
10	60095	2	Nut, .312-18 serrated flange	
11	60237	6	Washer, #10 flat .495/.036	
12	60457	6	Nut, 10-24 nylock, G2	
13	10000036081	1	Assembly, right side door	Items 1-12

ELECTRICAL BOXES TO UNIT

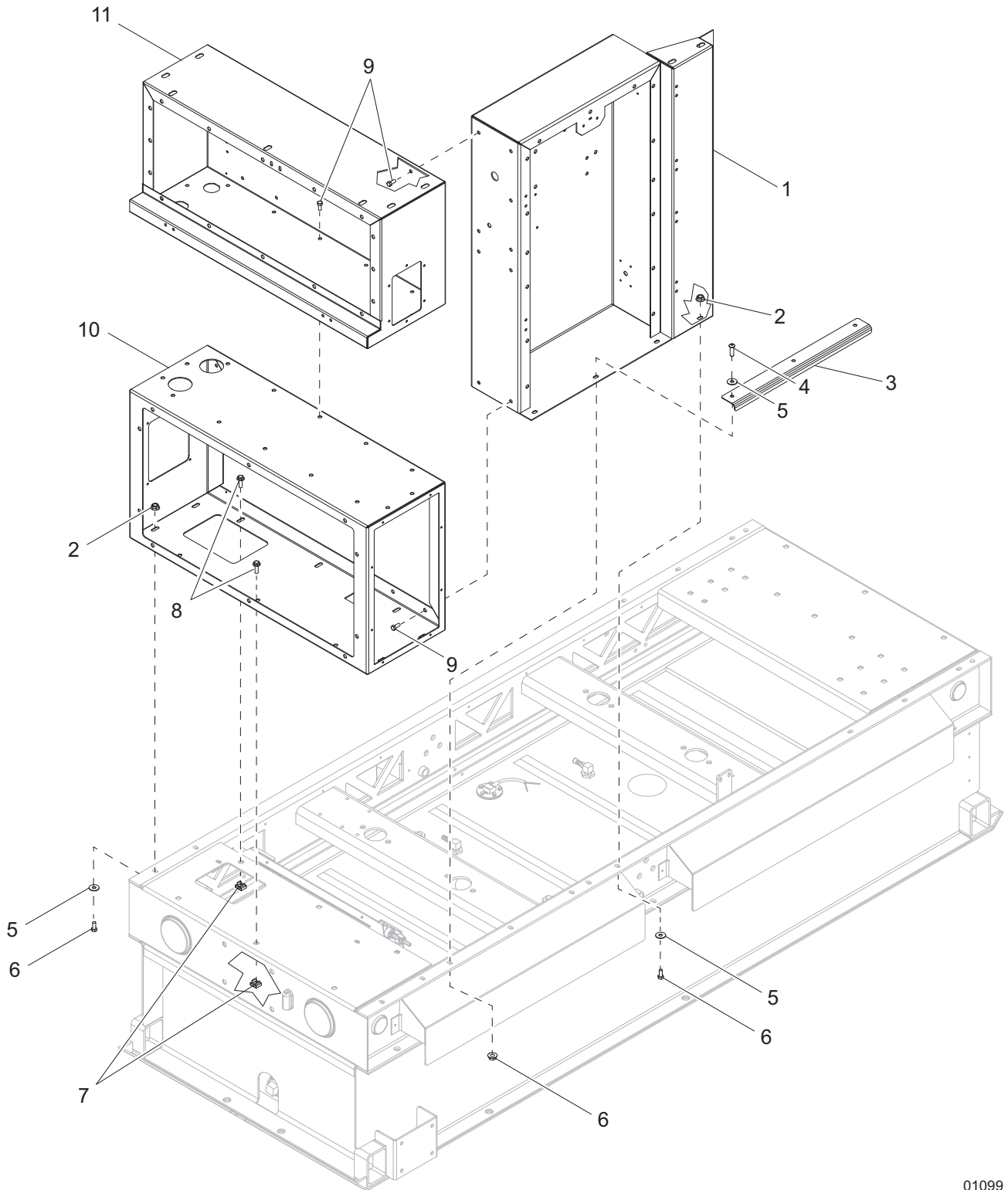

01099

ELECTRICAL BOXES TO UNIT

Item	Part No.	Qty	Description	Notes
1	10000036130	1	Assembly, AC box	
2	60095	7	Nut, .312-18 serrated flange	
3	37817B	1	Guide, cable	
4	60654	3	Screw, .312-18 x 1.0 button hex, SS	
5	60340	7	Washer, .312 flat .875/.040, SS	
6	60507	4	Screw, .312-18 x 1.0 standard hex, SS	
7	15425	5	Nut, .312-18 cage	
8	60616	5	Screw, .312-18 x .750 serrated flange hex, G5	
9	62052	23	Screw, .312-18 x .500 serrated flange hex, G5	
10	10000036067	1	Assembly, bottom rear box	Page 28
11	10000036077	1	Assembly, control box	Page 32

FRONT ENCLOSURE ASSEMBLY

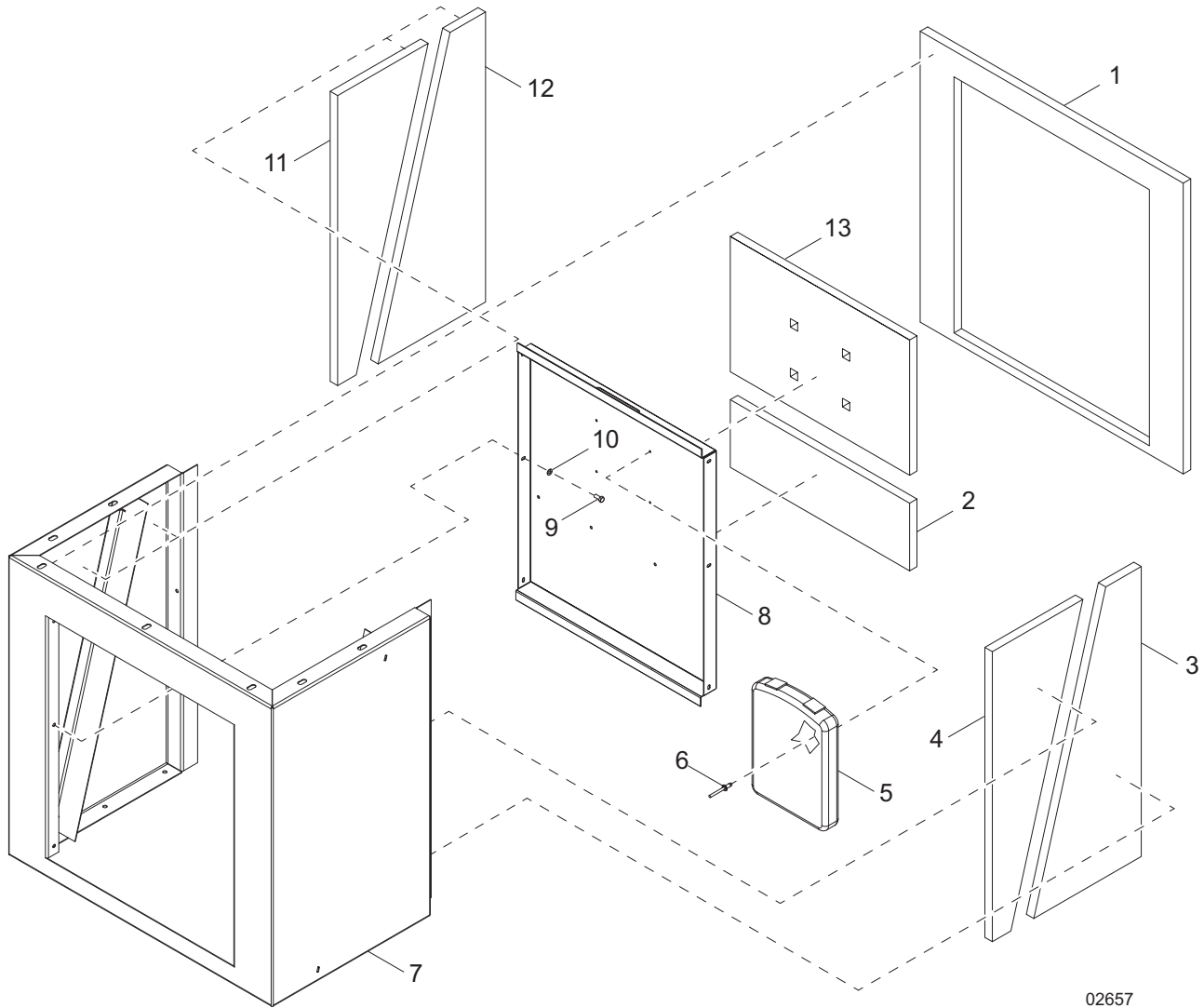

02657

FRONT ENCLOSURE ASSEMBLY

Item	Part No.	Qty	Description	Notes
1	37111SRV	1	Foam, front enclosure	
2	10000036114	1	Foam, front panel - lower	
3	37110SRV	1	Foam, front enclosure - left bottom	
4	37108SRV	1	Foam, front enclosure - left top	
5	24540	1	Manual holder	
6	60195	4	Rivet, .188 diameter x .375 to .500 grip	
7	51296W	1	Panel, front insert for deflector	
8	36932W	1	Weldment, front enclosure	
9	60620	6	Screw, .250-20 x 1.0 standard hex, SS	
10	60696	6	Washer, .250 flat .625/.050, SS	
11	37106SRV	1	Foam, front enclosure - right top	
12	37109SRV	1	Foam, front enclosure - right bottom	
13	10000036101	1	Foam, front panel - upper	

AC BOX ASSEMBLY (1 OF 2)

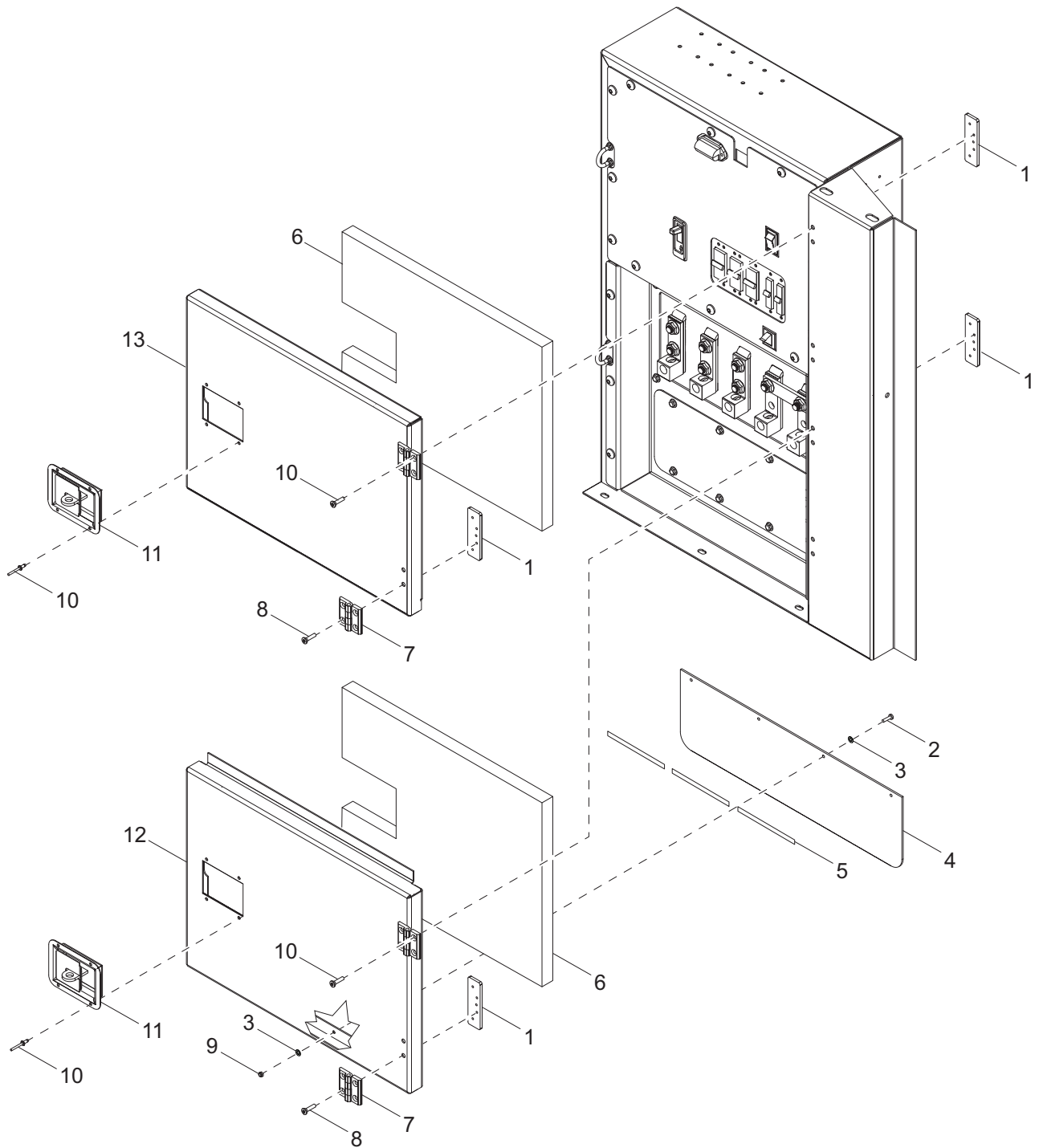

02658

AC BOX ASSEMBLY (1 OF 2)

Item	Part No.	Qty	Description	Notes
1	37136ZC	8	Plate, hinge back - threaded	
2	60540	4	Screw, 10-24 x .750 pan Phillips, SS	
3	60067	8	Washer, #10 flat .435/.060, SS	
4	35732	1	Flap, lug door	
5	50192	1.5 ft	Tape, .500 in., double sided, type VHB	
6	10000036120	2	Foam	
7	35394	4	Hinge, door	
8	35290	16	Screw, 10-24 x 1.0 flat head Phillips, SS	
9	60457	4	Nut, 10-24 nylock, G2	
10	60268	8	Rivet, .188 diameter. x .126 to .250 grip, SS	
11	37145B	2	Latch, paddle - mini	
12	35356W	1	Door, lug/cam door	
13	35355W	1	Door, breaker	
--	50187	8.2 ft	Weatherstripping - .06 x 1.0	

AC BOX ASSEMBLY (2 OF 2)

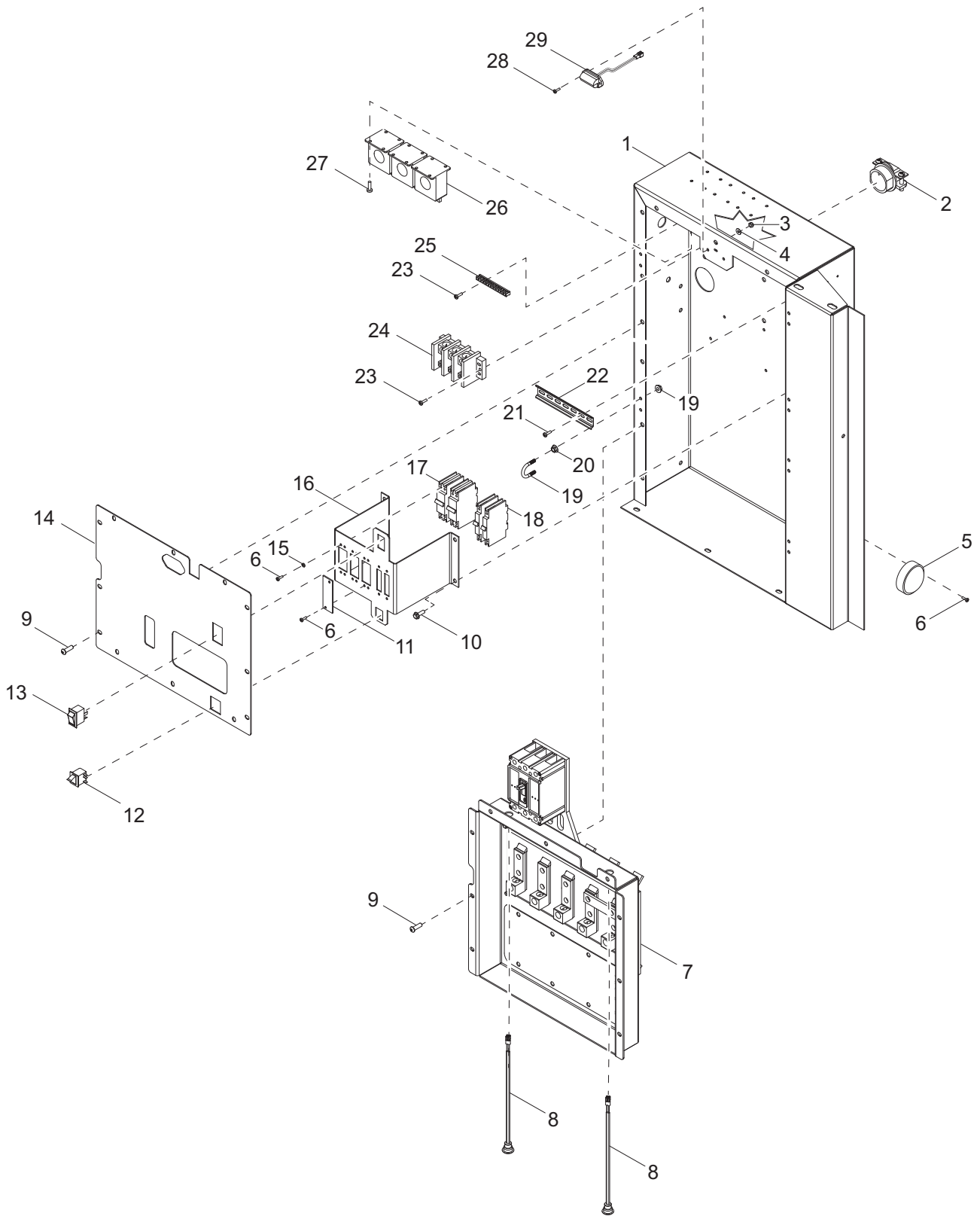

02672

Item	Part No.	Qty	Description	Notes
1	37226W	1	Weldment, AC box	
2	65788	1	Strain relief - 2.0 Romex w/nut	
3	60270	2	Nut, 8-32 nylock, class 6	
4	60269	2	Washer, #8 flat .433/.036	
5	68262	1	Assembly, LED light - 12V oval	
6	60046	22	Screw, 6-32 x .750 pan Phillips, G2	
7	10000033285	1	Assembly, lug box	Page 26
8	36964	2	Assembly, controls light	
9	33942	18	Screw, .312-18 x .750 button socket cap, G5	
10	60616	4	Screw, .312-18 x .750 serrated flange hex, G5	
11	53785	1	Plate, cover 2 pole 50A breaker	
12	66089	1	Switch, trigger safety, NO terminals	
13	66995	1	Switch, rocker - on/off	
14	37230W	1	Panel, AC box breaker	
15	60058	16	Washer, #6 split lock	
16	35387B	1	Bracket, breaker	
17	18092	3	Breaker, 50A, 240V, 2-pole	
18	18091	2	Breaker, 20A, 240V, 1-pole	
19	63172	2	U-bolt, .250-20 x 1.0 OD tube	
20	60161	8	Nut, .250-20 serrated flange, G5	
21	60062	2	Screw, 10-32 x .750 pan Phillips, G2	
22	67129	1	Rail, din - 35mm x 7.0 in	
23	60397	4	Screw, 10-32 x 1.0 pan Phillips, G2	
24	65356	1	Block, terminal - 3 pole, Bussman	
25	14204	1	Kit, ground bar	
26	65685	3	Transformer, current - terminals (200:5A)	
27	60277	12	Screw, 10-32 x .500 pan Phillips, G2	
28	60694	2	Screw, 8-32 x .750 pan Phillips, SS	
29	36879	1	Light, license plate	
--	68143	1	Wire group - power box	
--	50187	5.67 ft	Seal, door - D-shaped	Used on item 24
--	50187	4.10 ft	Seal, door - D-shaped	Used on item 18
--	68113	1	Assembly, terminal block - PT2.5, 7 position	
<i>Buck Transformer: (if equipped)</i>				
--	66340	1	Relay, voltage sensing (132 in, 126 out)	
--	65644	1	Base, relay - 8 position	
--	65461	1	Relay, 30A DPDT 120VAC power	

LUG BOX ASSEMBLY

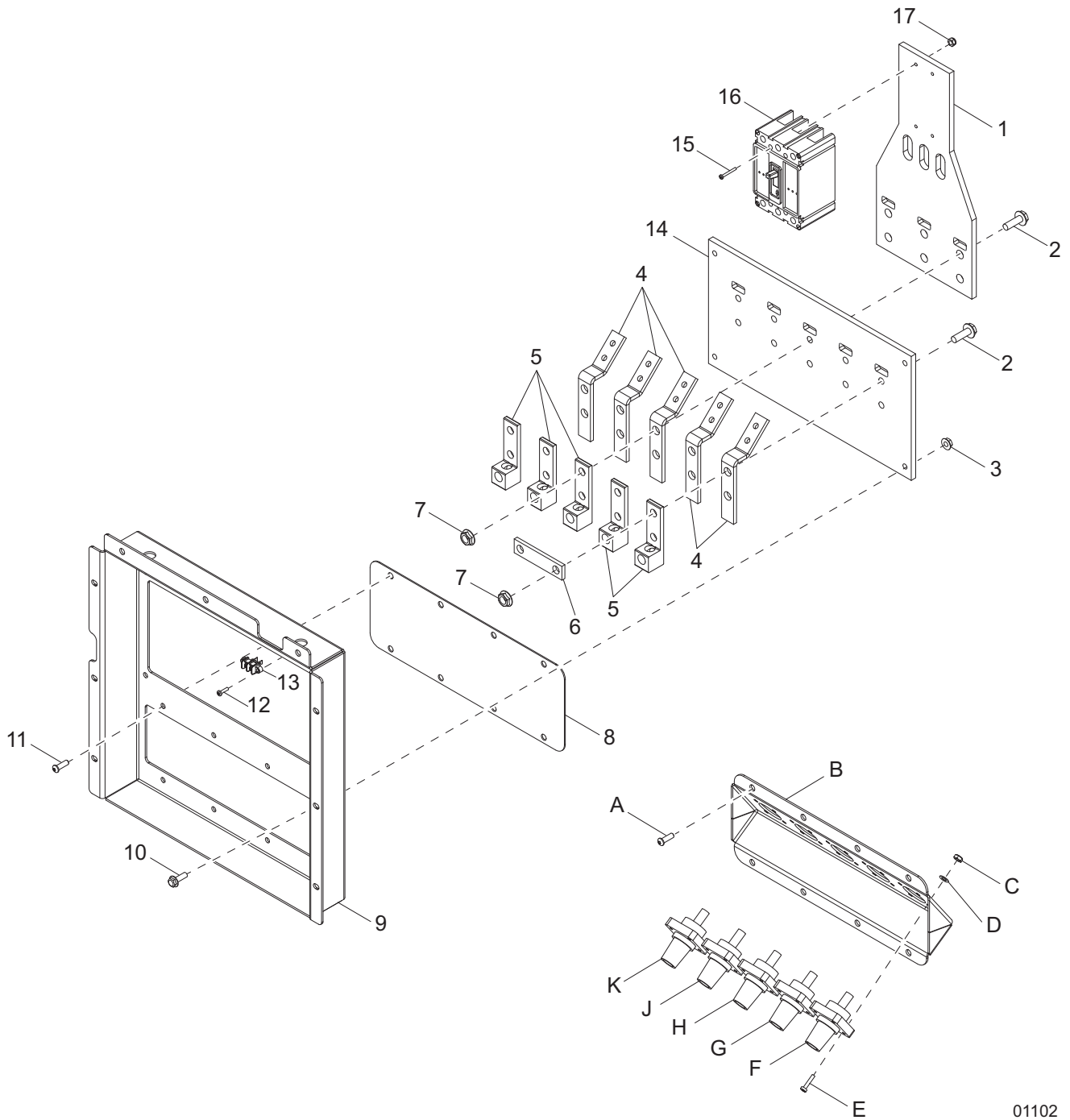

01102

LUG BOX ASSEMBLY

Item	Part No.	Qty	Description	Notes
1	37446	1	Panel, Glastic lug/breaker	
2	61103	10	Screw, .500-13 x 1.750 serrated flange hex	
3	60095	4	Nut, .312-18 serrated flange	
4	35389	5	Bus, lug	
5	65677	5	Lug, terminal single - 2 hole	
6	37218	1	Bus, neutral to ground	
7	60098	10	Nut, .500-13 serrated flange	
8	37336B	1	Plate, cams block-off	
9	37219W	1	Panel, lug/cam	
10	61091	4	Screw, .312-18 x 1.0 serrated flange hex, G5	
11	69668	8	Screw, .312-18 x .750 button head, G5	
12	60488	2	Screw, 8-32 x .750 pan Phillips, G2, self tapping	
13	68080	1	Block, terminal - 2 position feed thru	
14	35388	1	Panel, Glastic lug	
15	60159	4	Screw, M4-.70 x 45 pan Phillips, G4.8	
16	65446	1	Breaker, 125A	not included with 10000033285
17	60051	4	Nut, M4-.7 nylock, G8.8	
<i>Cam Locks: (if equipped)</i>				
A	69668	8	Screw, .312-18 x .750 button head, G5	
B	37221B	1	Panel, cam lock	
C	60061	20	Nut, 10-32 nylock	
D	60237	20	Washer, #10 flat .495/.036	
E	60397	20	Screw, 10-32 x 1.0 pan Phillips, G2	
F	66041	1	Connector, cam lock flange female, 400A, green	
G	66040	1	Connector, cam lock flange female, 400A, white	
H	65553	1	Connector, cam lock flange female, 400A, blue	
J	65552	1	Connector, cam lock flange female, 400A, red	
K	65551	1	Connector, cam lock flange female, 400A, black	
--	68179	1	Wire group - cam locks, single	

BOTTOM REAR BOX ASSEMBLY

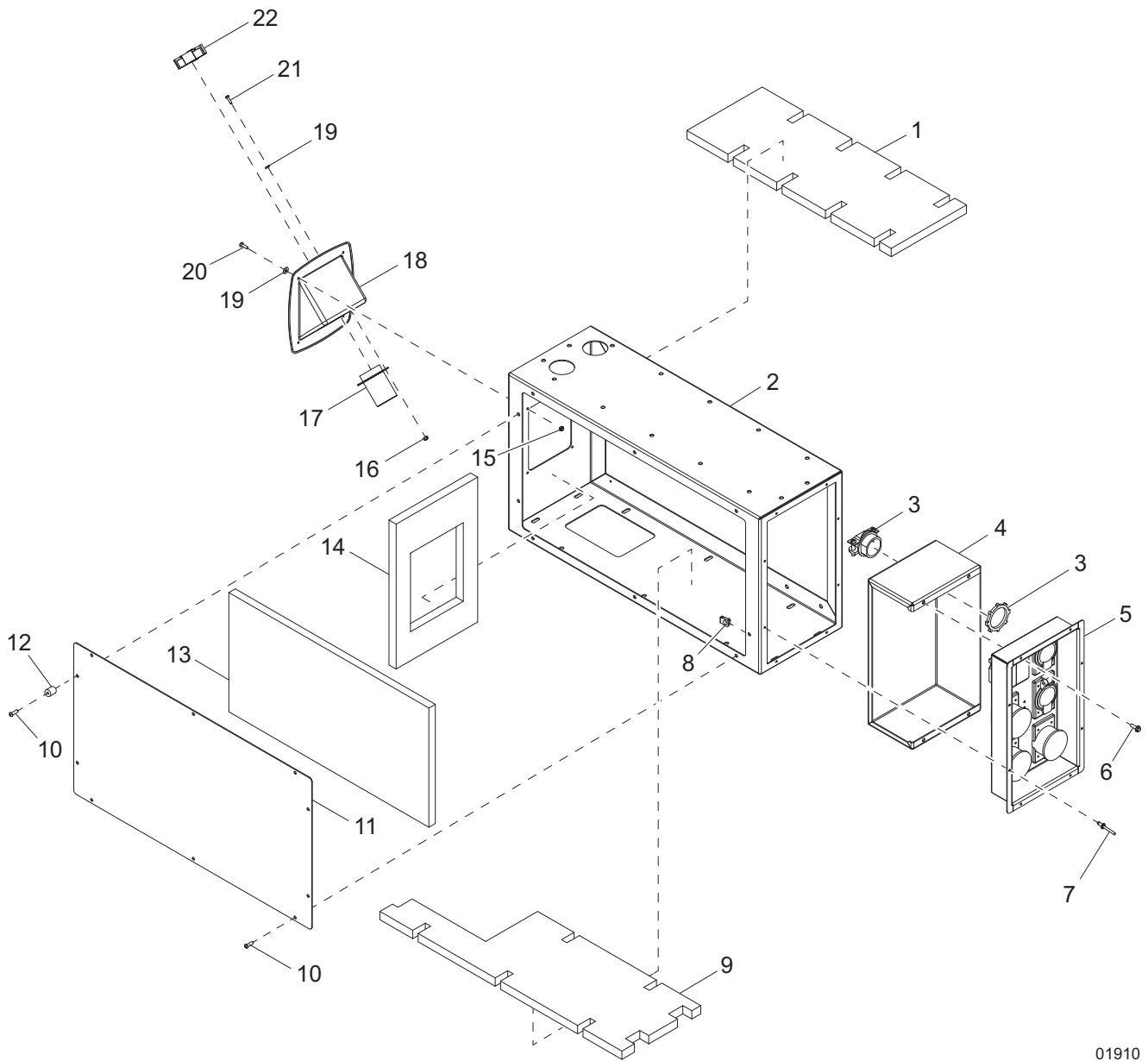

01910

BOTTOM REAR BOX ASSEMBLY

Item	Part No.	Qty	Description	Notes
1	10000018640	1	Foam, bottom rear box - top	
2	35413W	1	Box, bottom rear	
3	65788	1	Strain relief - 2.0 Romex w/nut	
4	37229B	1	Panel, buck transformer mounting	
5	10000036131	1	Assembly, receptacle panel	
6	60479	4	Screw, .250-20 x 1.0 serrated flange hex, G5	
7	60260	8	Rivet, .188 diameter x .375 to .500 grip, SS	
8	61143	10	Nut, .250-20 U-clip - short type	
9	10000018611	1	Foam, bottom rear box - lower	
10	68070	10	Screw, .250-20 x 1.0 button hex, SS	
11	37231W	1	Panel, bottom rear box	
12	37869	2	Bumper, round - 1.25 diameter x 1.25H	
13	10000018631	1	Foam, bottom rear box - face	
14	10000018621	1	Foam, bottom rear box - side	
15	60457	4	Nut, 10-24 nylock, G2	
16	60530	3	Nut, 10-24 nylock, SS	
17	18506	1	Port, fuel fill	
18	37626B	1	Weldment, filler tube and flange - 2.75 in. OD	
19	60067	7	Washer, #10 flat .435/.060, SS	
20	60540	4	Screw, 10-24 x .750 pan Phillips, SS	
21	60529	3	Screw, 10-24 x .6258 pan Phillips, SS	
22	18648	1	Cap, fuel fill w/gasket	

RECEPTACLE PANEL ASSEMBLY

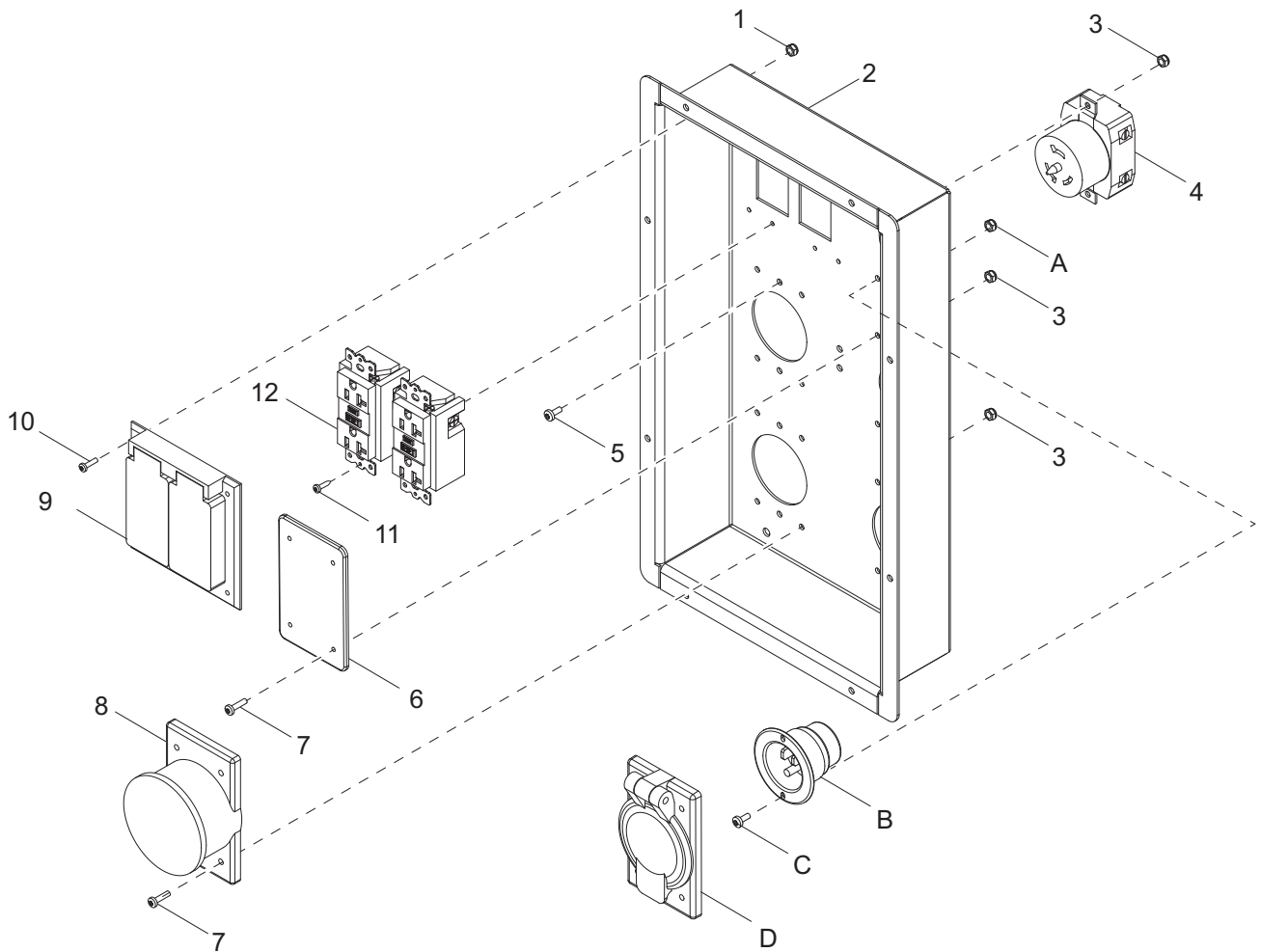

02660

RECEPTACLE PANEL ASSEMBLY

Item	Part No.	Qty	Description	Notes
1	60290	4	Nut, 6-32 nylock, SS	
2	35415B	1	Panel, receptacle	
3	60270	24	Nut, 8-32 nylock, class 6	
4	18089	2	Receptacle, 240V/50A twist-lock	
5	62054	4	Screw, 8-32 x .500 pan Phillips, SS	
6	68453	3	Cover, receptacle - block off	
7	60694	24	Screw, 8-32 x .750 pan Phillips, SS	
8	65467	3	Cover, receptacle - weatherproof 50A twist	
9	15849	1	Cover, receptacle - weatherproof 20A GFCI dual	
10	62210	4	Screw, 6-32 x .500 pan Phillips, SS	
11	60424	4	Screw, 6-32 x .750 pan Phillips, G2, self threading	
12	14130	2	Receptacle, 120V/20A GFCI	

Receptacles: (if equipped)

A	60728	4	Nut, 6-32 nylock, G5
B	65285	2	Receptacle, 120V/15A inlet (Edison)
C	61193	4	Screw, 6-32 x .375 pan Phillips, SS
D	36939	2	Cover, receptacle - weatherproof 20/30A

CONTROL BOX ASSEMBLY

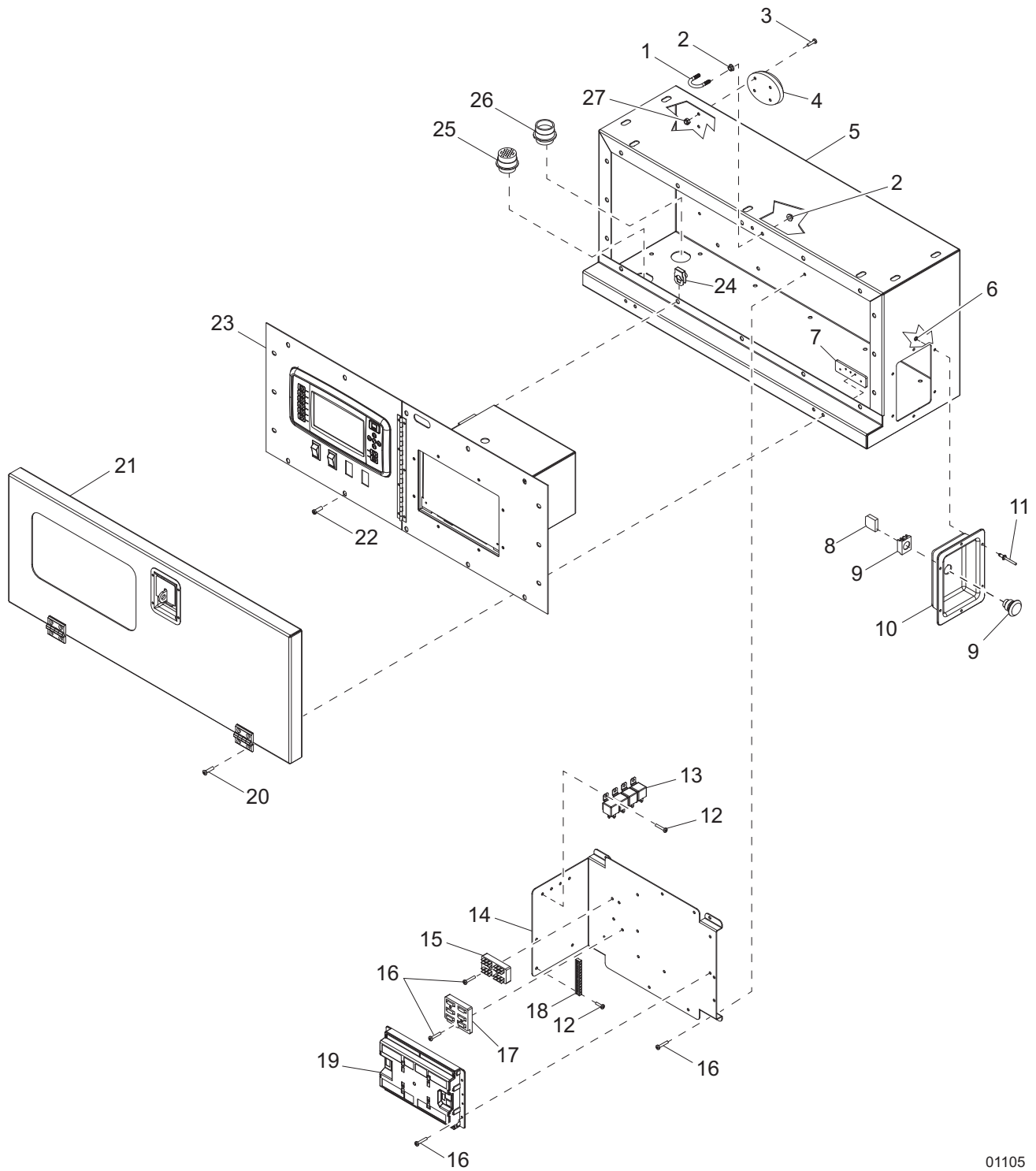

01105

CONTROL BOX ASSEMBLY

Item	Part No.	Qty	Description	Notes
1	68288	1	U-bolt, .250-20 x 1.13 OD x 2.0 leg tube	
2	60161	4	Nut, .250-20 serrated flange, G5	
3	60046	4	Screw, 6-32 x .750 pan Phillips, G2	
4	68262	1	Light, assembly - 12V LED oval	
5	35348W	1	Box, control	
6	60067	6	Washer, #10 flat .435/.060, SS	
7	37136ZC	2	Plate, hinge back - threaded	
8	65580	1	Block, emergency stop contactor - NC	
9	65470	1	Switch, emergency stop operator	
10	30645	1	Panel, emergency stop	
11	60260	6	Rivet, .188 diameter x .375 to .500 grip, SS	
12	60062	6	Screw, 10-32 x .750 pan Phillips, G2	
13	68106	4	Relay, 12V 30/50A NO w/diode	
14	37481W	1	Bracket, DC controls	
15	66992	1	Block, terminal - 4 x 6 push-on	
16	60277	12	Screw, 10-32 x .500 pan Phillips, G2	
17	68203	1	Fuse holder, 6 bank, type mini	
18	14204	1	Kit, ground bar	
19	68926	1	Controller, standard tank	
20	35290	4	Screw, 10-24 x 1.0 flat Phillips, SS	
21	10000036048	1	Assembly, control door	
22	68070	16	Screw, .250-20 x 1.0 button hex, SS	
23	10000036966	1	Assembly, control panel	<i>Page 34</i>
24	61143	16	Nut, .250-20 U-clip - short type	
25	28704	1	Connector, Deutsch 31 position receptacle	
26	65309	1	Connector, Deutsch 21 position receptacle	
27	60728	4	Nut, 6-32 nylock, G5	
--	68130	1	Harness, control box	

Note: To order replacement controller, contact Generac Mobile Products with unit serial number

CONTROL PANEL ASSEMBLY

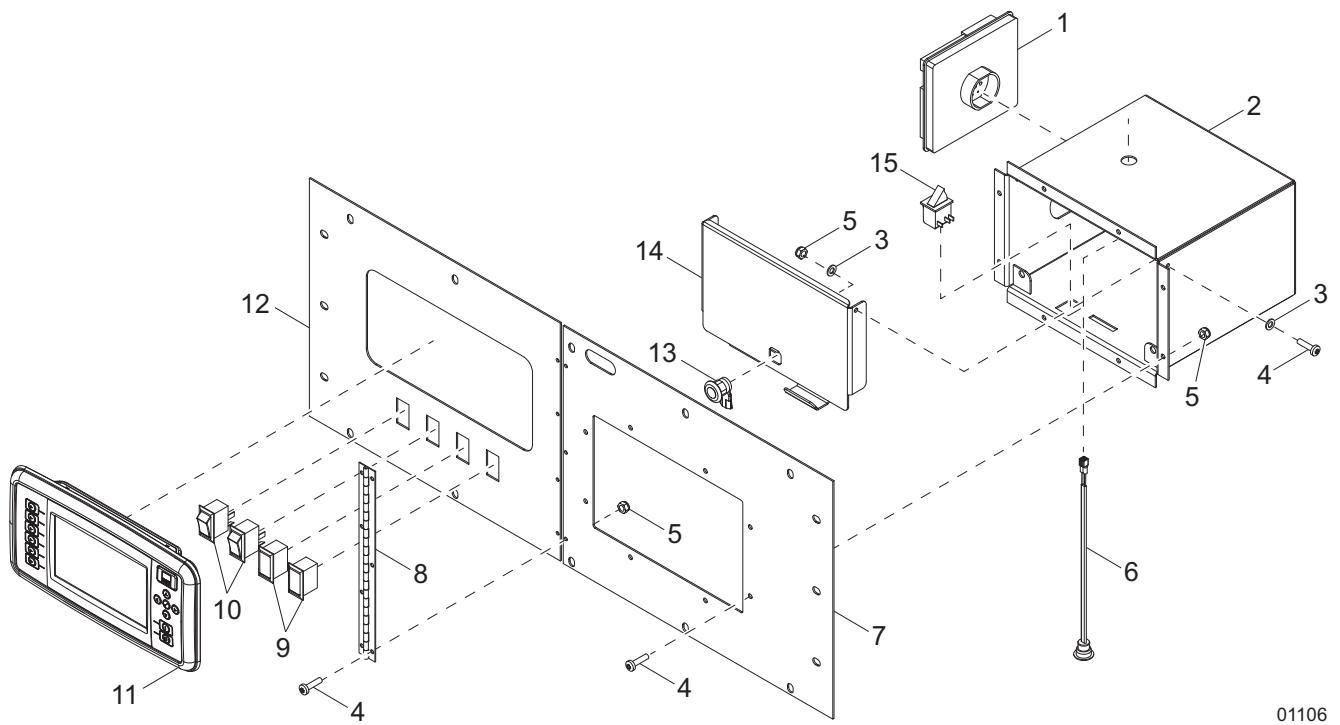

01106

CONTROL PANEL ASSEMBLY

Item	Part No.	Qty	Description	Notes
1	68015	1	Regulator, voltage - PM600	
2	37129W	1	Weldment, phase switch box	
3	60237	4	Washer, #10 flat .495/.036	
4	60277	17	Screw, 10-32 x .500 pan Phillips, G2	
5	60061	17	Nut, 10-32 nylock	
6	36964	1	Assembly, controls light	
7	37490W	1	Panel, phase switch	
8	13677	1	Hinge, continuous - 11.0 in	
9	34439	2	Plug, panel switch - 1.91 x .96	
10	66995	2	Switch, rocker - on/off	
11	33157	1	Display, 7 in. DSE	
12	37496W	1	Panel, PZ display	
13	20762	1	Lock, door - 1/4 turn cam	
14	37824W	1	Door, phase switch	
15	66089	1	Switch, trigger safety - NO terminals	

CONTROL DOOR ASSEMBLY

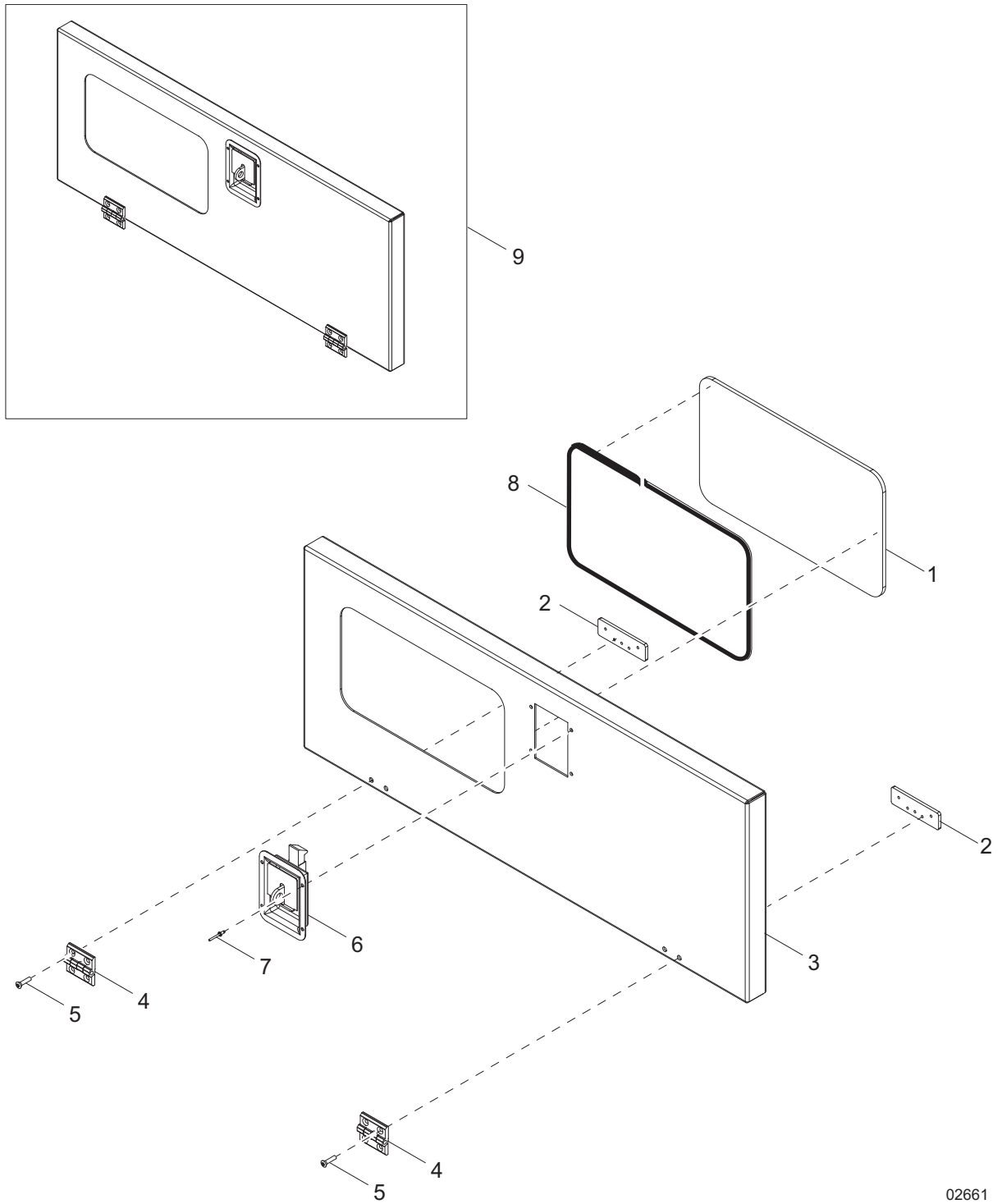

02661

CONTROL DOOR ASSEMBLY

Item	Part No.	Qty	Description	Notes
1	35854	1	Window, control door - UV	
2	37136ZC	2	Plate, hinge back	
3	35346W	1	Door, control	
4	35394	2	Hinge, door	
5	35290	4	Screw, 10-24 x 1.0 flat head Phillips, SS	
6	37145B	1	Latch, paddle - mini, black	
7	60268	4	Rivet, .188 diameter x .126 to .250 grip, SS	
8	50192	4 ft	Tape, .500 in., double sided, type VHB	
9	10000036048	1	Assembly, control door	Items 1-8
--	50187	8.08 ft	Seal, door - D-shaped (.750)	

LIFT STRUCTURE TO SKID ASSEMBLY

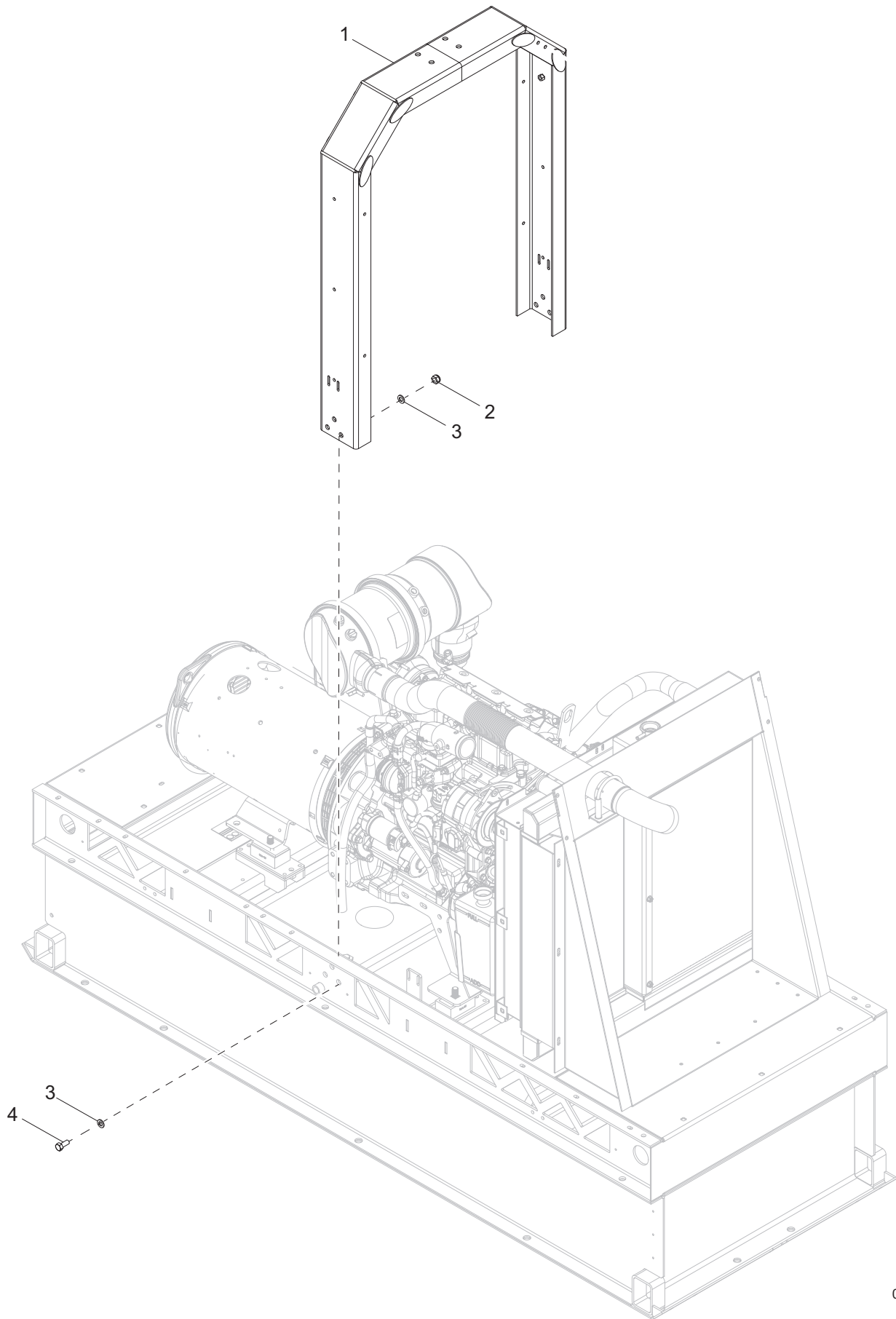

02662

LIFT STRUCTURE TO SKID ASSEMBLY

Item	Part No.	Qty	Description	Notes
1	52416B	1	Weldment, lift structure	
2	62221	6	Nut, .500-13 nylock, G5	
3	60309	12	Washer, .500 flat 1.060/.090	
4	60388	6	Screw, .500-13 x 1.50 standard hex, G5	

COOLING SYSTEM ASSEMBLY

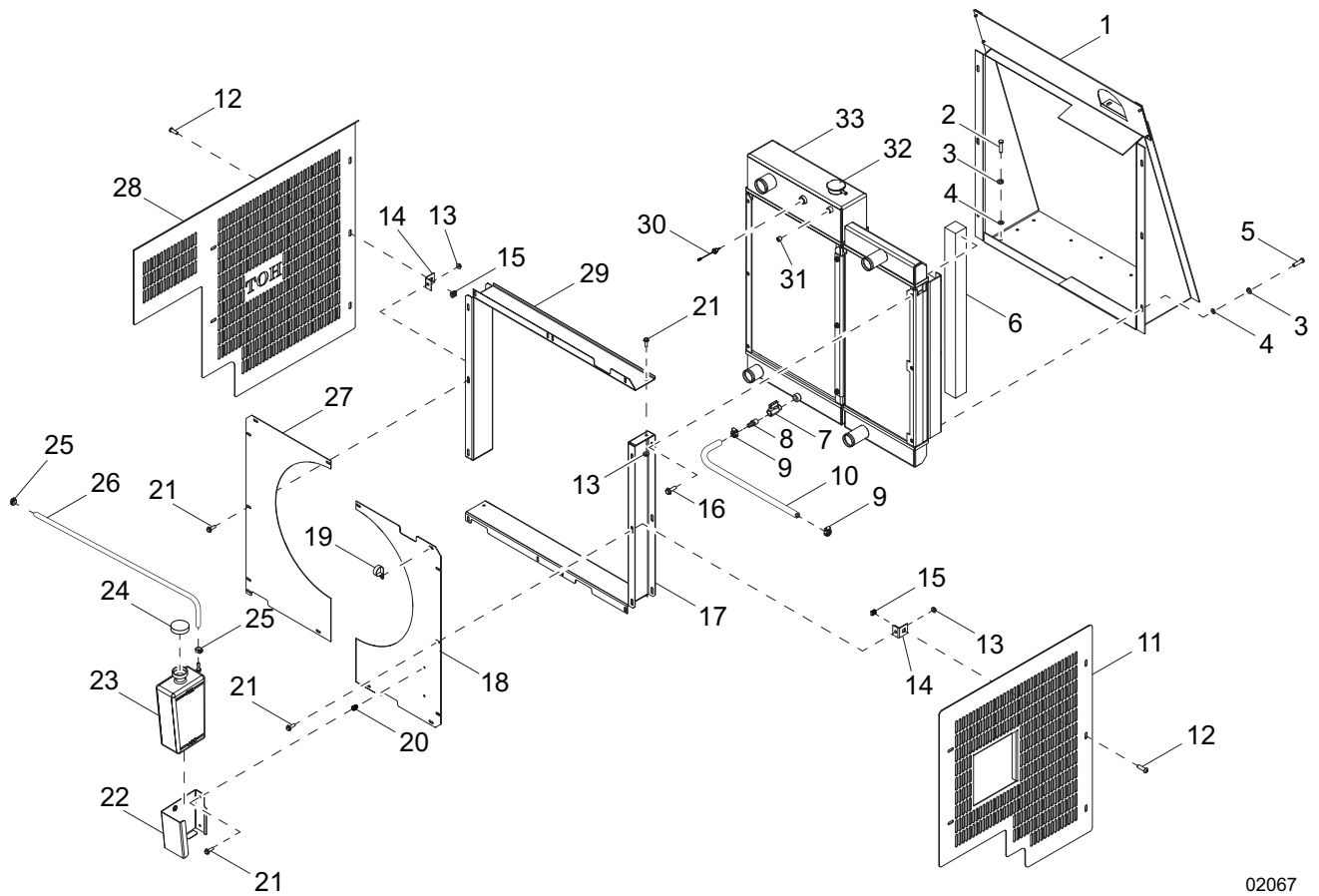

02067

COOLING SYSTEM ASSEMBLY

Item	Part No.	Qty	Description	Notes
1	38476B	1	Assembly, bulkhead	
2	60507	6	Screw, .312-18 x 1.0 standard hex, SS	
3	60701	12	Washer, .312 split lock, SS	
4	60340	12	Washer, .312 flat .875/.040, SS	
5	60687	6	Screw, .312-18 x .750 standard hex, SS	
6	10000036078	1	Foam, under radiator	
7	62032	1	Valve, ball - .375NPTF, mini	
8	19180	1	Fitting, strt - .375MNPT x .312 barb	
9	14216	2	Clamp, hose - SAE (.21-.62) mini	
10	50018	.85 ft	Hose, fuel - .312 ID, 50 psi, SAE 30R7	
11	52643B	1	Guard, right	
12	69668	10	Screw, .312-18 x .750 button head, G5	
13	60161	16	Nut, .250-20 serrated flange, G5	
14	37471B	6	Bracket, fan guard	
15	15425	6	Nut, .312-18 cage	
16	60616	6	Screw, .312-18 x .750 serrated flange hex, G5	
17	52608B	1	Shroud, radiator - bottom	
18	52739B	1	Panel, fan shroud - right	
19	60649	1	Clamp, tubing .750 heavy-duty	
20	62132	2	Insert, threaded - .250-20 splined, .027-.165	
21	60175	18	Screw, .250-20 x .500 serrated flange hex, G5	
22	26211B	1	Bracket, overflow jug	
23	24952	1	Jug, overflow - 2.5 qt	
24	19714	1	Cap, overflow jug	
25	63192	2	Clamp, crimping band - .464 in	
26	50017	.85 ft	Hose, fuel .250 ID 50 PSI SAE 30R7	
27	52738B	1	Panel, fan shroud - left	
28	52642B	1	Guard, left	
29	52607B	1	Shroud, radiator - top	
30	68206	1	Sensor, low coolant - wet sinking	
31	60776	1	Fitting, plug - .250NPT hex flush mount, brass	
32	19219	1	Cap, radiator	
33	51315	1	Radiator, 12.5 in. CAC, 16.5 in. rad	

COOLING SYSTEM HOSES

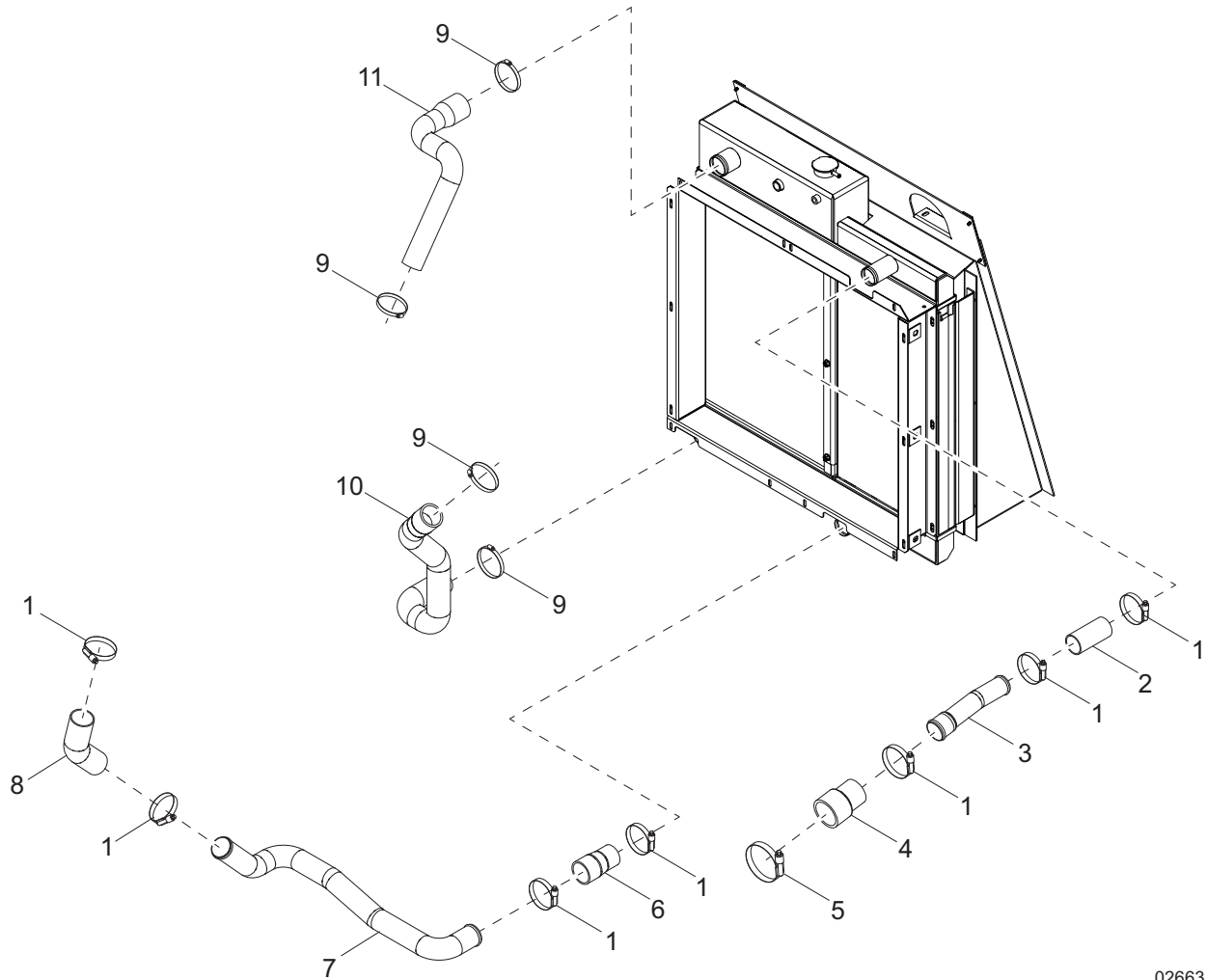

02663

COOLING SYSTEM HOSES

Item	Part No.	Qty	Description	Notes
1	60660	7	Clamp, hose - constant torque 1.75-2.625	
2	33912	1	Hose, CAC - 1.75 x 4.0 long	
3	52672	1	Pipe, CAC - upper	
4	22060	1	Hose, CAC - 2.0-2.50 x 4.0 long	
5	60666	1	Clamp, hose - constant torque 2.25-3.125	
6	27993	1	Hose, CAC - 1.75-2.0 x 4.0 long	
7	52670	1	Pipe, CAC - lower	
8	32155	1	Hose, CAC - 2.0 x 45°	
9	60316	4	Clamp, hose - SAE 032 (1.56-2.50)	
10	52667	1	Hose, radiator - lower	
11	52666	1	Hose, radiator - upper	

ENGINE AND GENERATOR TO SKID ASSEMBLY

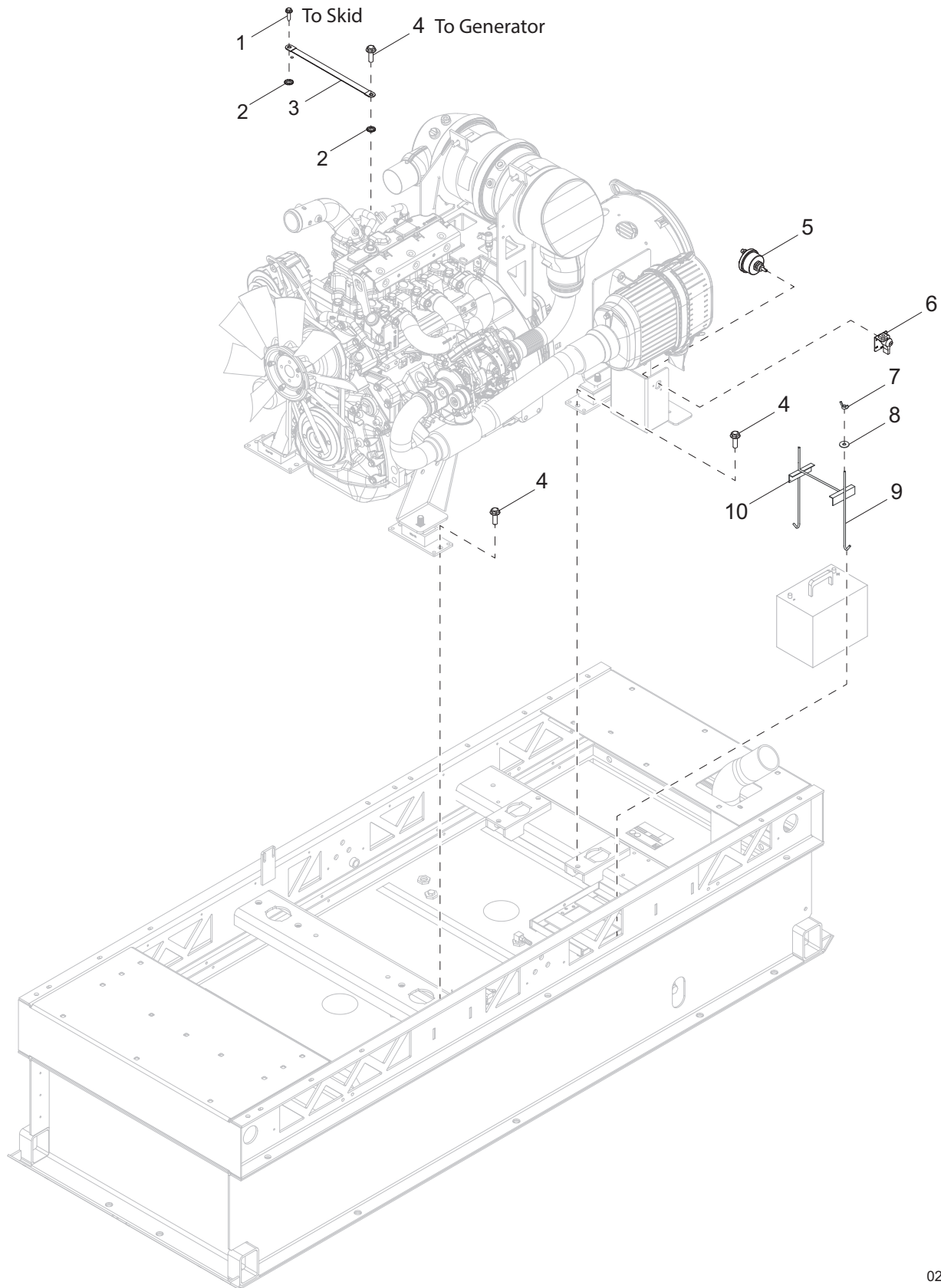

02664

ENGINE AND GENERATOR TO SKID ASSEMBLY

Item	Part No.	Qty	Description	Notes
1	60353	1	Screw, .375-16 x 1.0 flange hex, self-tapping, G2	
2	60053	4	Washer, .375 external star	
3	22438	1	Strap, braided ground - 16 in	
4	60018	9	Screw, M10-1.50 x 20 serrated flange hex, class 90	
5	65498	1	Switch, disconnect	
6	65499	1	Switch, lockout lever	
7	60090	2	Nut, .250-20 wing, G5	Included w/item 9
8	60089	2	Washer, .265 fender 1.250/.060	Included w/item 9
9	60820	2	Bolt, J - .250-20 x 9.0	
10	14682	1	Bracket, battery hold-down	

ENGINE ASSEMBLY

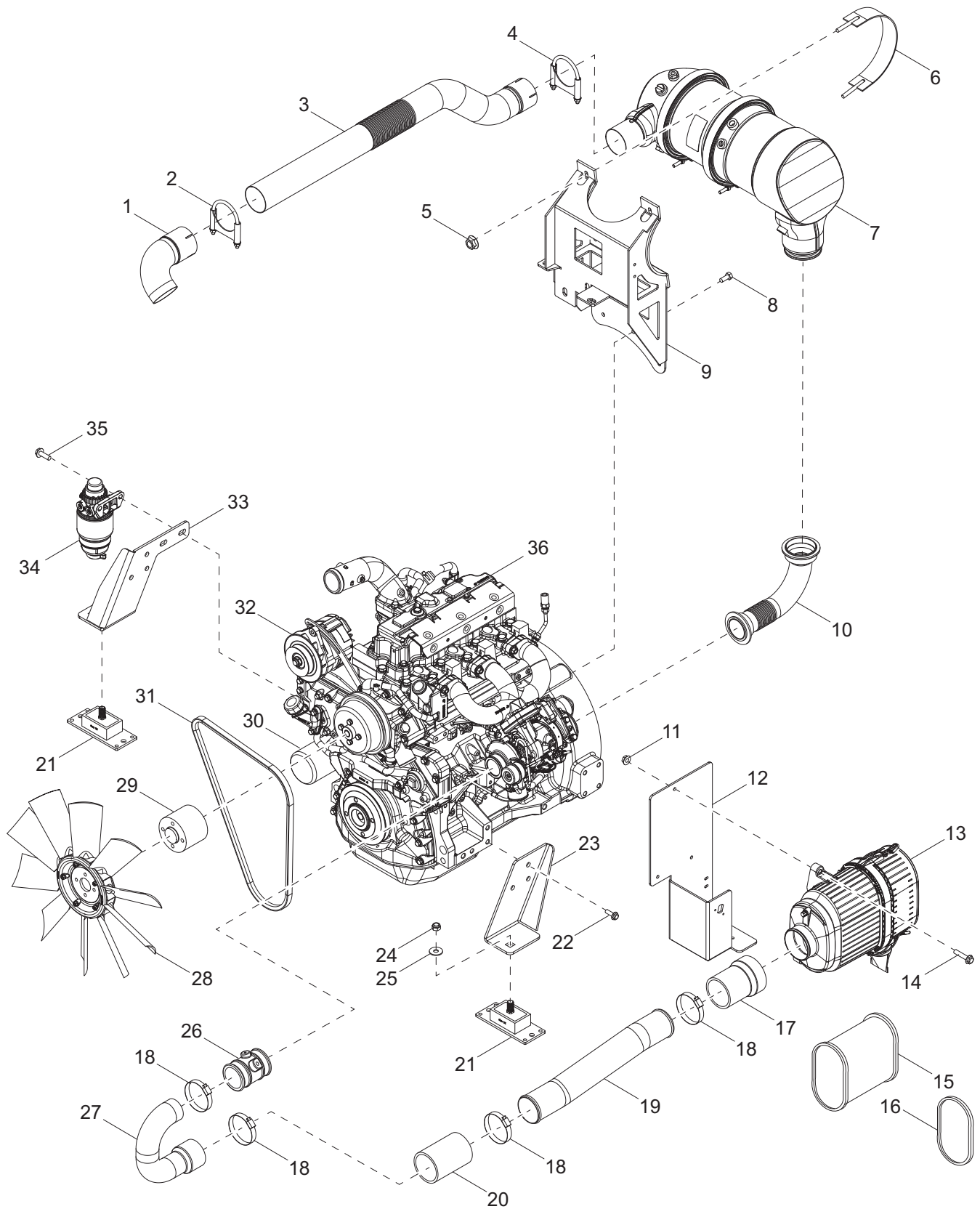

02665

ENGINE ASSEMBLY

Item	Part No.	Qty	Description	Notes
1	53175	1	Pipe, exhaust 3.00 - 90° - short	
2	18821	1	Clamp, muffler 3.00	
3	52664	1	Pipe, exhaust - filter outlet	
4	52359	1	Clamp, V-band 3.66 ID	
5	60095	4	Nut, .312-18 serrated flange	
6	52965	2	Strap, DPF	
7	37890	1	Filter, exhaust	
8	60018	3	Screw, M10-1.50 x 20 serrated flange hex	
9	52874B	1	Weldment, DOC/DPF	
10	51055	1	Weldment, turbo exhaust out	
11	60095	3	Nut, .312-18 serrated flange hex	
12	52631B	1	Bracket, air filter	
13	52736	1	Assembly, air filter	
14	60534	3	Screw, .312-18 x 1.750 serrated flange hex	
15	68894	1	Element, air filter-primary	
16	68895	1	Element, air filter-secondary	
17	52630	1	Hose, air intake	
18	60316	4	Clamp, hose SAE 032 (1.56-2.50)	
19	52598	1	Pipe, air filter outlet	
20	51129	1	Hose - air intake	
21	52944	2	Isolator, rubber 360 lbs axial load - rectangular	
22	60072	6	Screw, M12-1.75 x 25 serrated flange hex, G10.9	
23	53239B	1	Bracket, engine mount - left	
24	69802	2	Nut, M16-2.0 nylock, G10	
25	60193	2	Washer, M16 flat	
26	10000037596	1	Air intake	
27	38519	1	Pipe, air filter inlet	
28	41121	1	Fan, pusher - 20.00 CW	
29	38490	1	Spacer, fan	
30	29487	1	Filter, oil	
31	51201	1	Belt, fan	
32	51205	1	Alternator	
33	53238B	1	Bracket, engine mount - right	
34	10000037567	1	Assembly, fuel filter	
35	60087	2	Screw, M6-1.00 x 16 serrated flange hex, G8.8	
36	50763	1	Engine, Deere G4 3029HFG03	
--	26061	1	Cap, oil	

GENERATOR ASSEMBLY

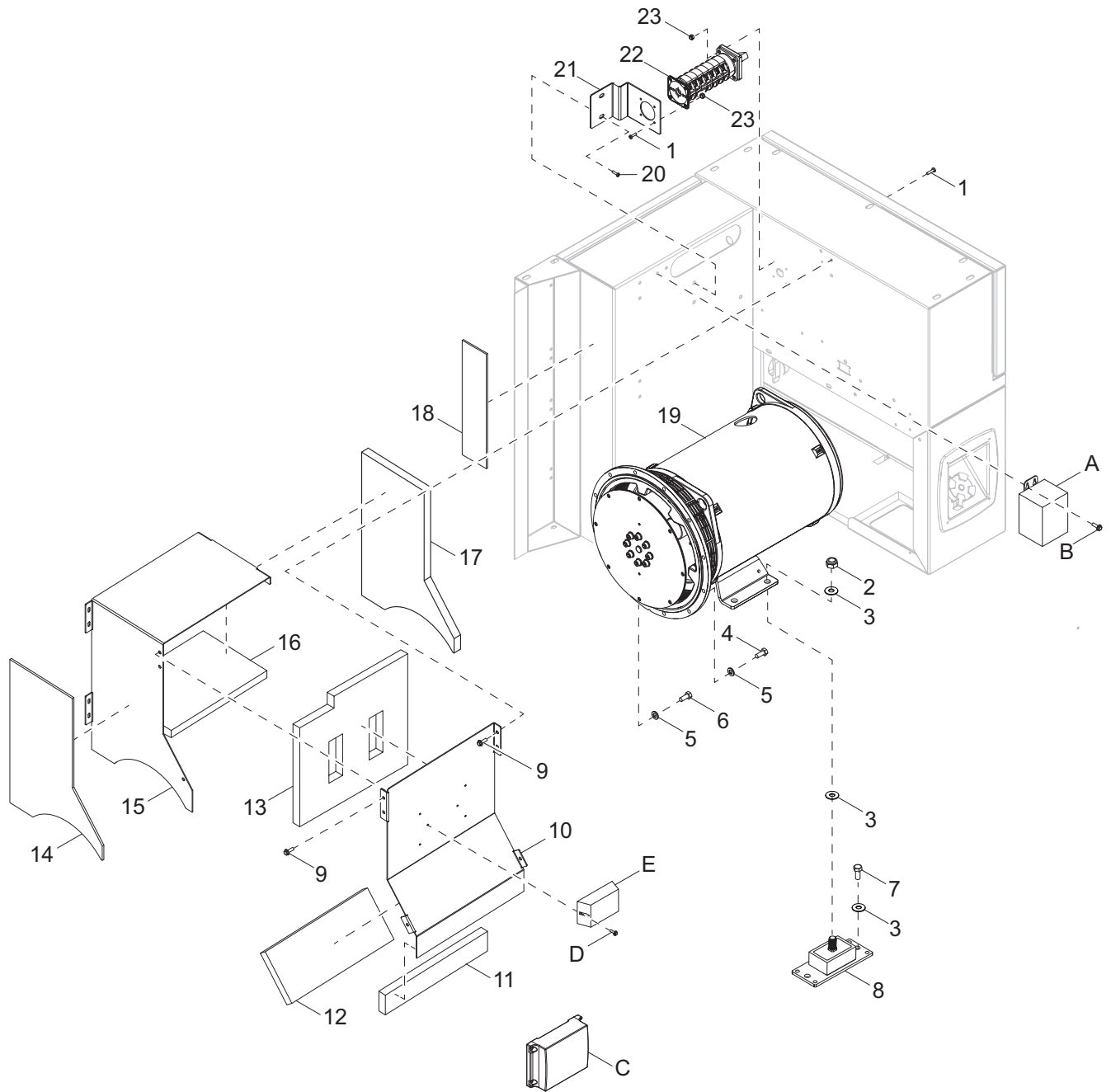

02671

GENERATOR ASSEMBLY

Item	Part No.	Qty	Description	Notes
1	60046	8	Screw, 6-32 x .750 pan Phillips, G2	
2	62221	2	Nut, .500-13 nylock, G5	
3	60416	4	Washer, .500 flat 1.375/.090	
4	60055	12	Screw, M10-1.50 x 35 standard hex, G10.9	
5	60026	20	Washer, M10 split lock	
6	63338	8	Screw, M10-1.50 x 20 hex, G10.9	
7	61101	2	Screw, .500-13 x 3.50 standard hex, G8	
8	52944	2	Isolator, neoprene, 360 lbs- rectangle	
9	60175	12	Screw, .250-20 x .500 serrated flange hex, G5	
10	52387W	1	Panel, generator cover - front	
11	10000036132	1	Foam, generator box - front bottom	
12	10000036121	1	Foam, generator box - front middle	
13	10000036928	1	Foam, generator box - front top	
14	10000036084	1	Foam, generator box - ceramic	
15	52388W	1	Panel, generator cover - side-top	
16	10000036140	1	Foam, generator box - top	
17	10000036122	1	Foam, generator box - side	
18	10000036103	1	Foam, AC box - ceramic	
19	52303	1	Generator, Marathon, 284CLS1542	
20	60616	2	Screw, .312-18 x .750 serrated flange hex, G5	
21	37860W	1	Bracket, phase switch	
22	37426	1	Switch, phase - 63A, 3 position (Y,y,Z)	
23	60728	8	Nut, 6-32 nylock, G5	
--	68301	1	Wire group - AC, 3 position	
--	65519	1	Block, terminal - 4 pole, stud type	
--	28628B	1	Plate, terminal block mounting	
--	10000036949	1	Assembly, generator	
<i>Buck Transformer: (if equipped)</i>				
A	21487	1	Transformer, 1.13:1 1-phase, 500VA (standard buck)	
B	60528	3	Screw, .250-20 x .625 serrated flange hex, G5	
--	68193	1	Wire group - buck transformer	
<i>Battery Chargers: (if equipped)</i>				
C	66212	1	Charger, battery - 2 - 5A/1 - 10A, 3 stage, 2 output	
D	60419	2 or 4	Screw, 6-32 x .500 flange hex, G2, self-tapping w/slot	Qty 2 for item E & qty 4 for item C
E	65326	1	Charger, battery - 2A, 3 stage, 1 output	
<i>4 Position Phase Switch: (if equipped)</i>				
--	37427	1	Switch, phase -63A, AC 4 position	
--	35391	1	Bracket, phase switch	
--	68303	1	Wire group - AC, 4 position	
<i>4 Position Phase Switch - 600V: (if equipped)</i>				
--	37144	1	Wire group - 80A, 4 position (600Y,Y,y,Z)	
--	68164	1	Wire group - AC, 4 position 600V	

SKID ASSEMBLY

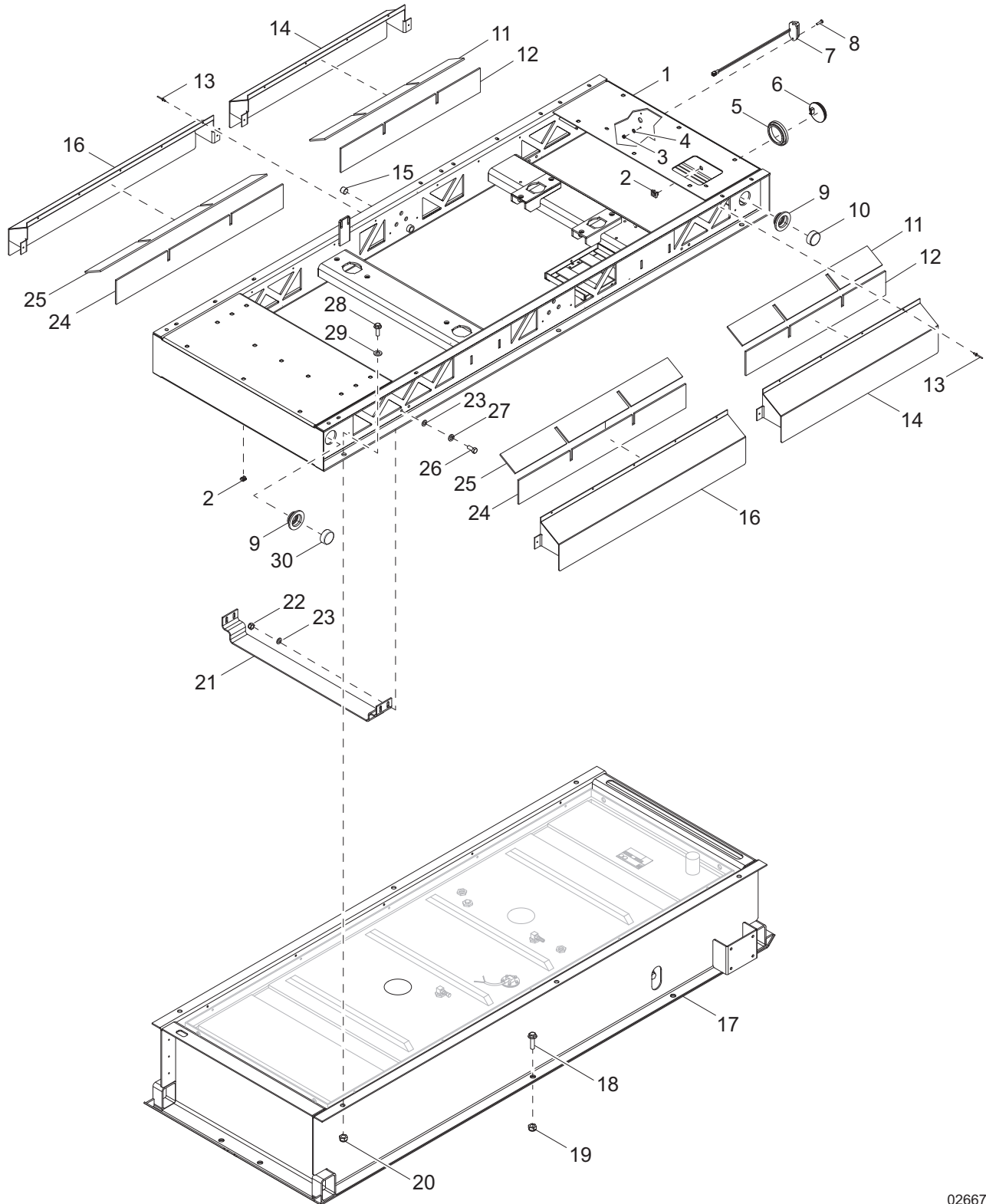

02667

SKID ASSEMBLY

Item	Part No.	Qty	Description	Notes
1	37827B	1	Weldment, mini skid	
2	15425	12	Nut, .312-18 cage	
3	60270	2	Nut, 8-32 nylock, class 6	
4	60269	2	Washer, #8 flat .433/.036	
5	10221	2	Grommet, rear light, rubber - 4.5 in	
6	66701	2	Light, rear tail/turn, round 4 in. - no grommet	
7	36963	1	Assembly, license plate light	
8	60694	2	Screw, 8-32 x .750 pan Phillips, SS	
9	66394	4	Grommet, sealed beam light, rubber - 2.0 in	
10	66703	2	Light, clearance, no grommet, 2.0 in. - red LED	
11	10000036104	2	Foam, rain shield - small top	
12	10000036116	2	Foam, rain shield - small bottom	
13	60260	26	Rivet, .188 diameter x .375 to .500 grip, SS	
14	51284B	2	Weldment, rain shield - short	
15	18394	2	Fitting, plug - .500NPT x internal hex	
16	51285B	2	Weldment, rain shield - long	
17	36921B	1	Weldment, lower skid	
18	63111	6	Screw, .750-10 x 2.250 flg hex, G8	
19	60584	6	Nut, .750-10 nylock, G5	
20	60240	6	Nut, .625-11 nylock, G5	
21	36985B	2	Bracket, fuel tank tie down	
22	60303	8	Nut, .312-18 nylock, G2	
23	60340	16	Washer, .312 flat .875/.040, SS	
24	10000036105	2	Foam, rain shield - large bottom	
25	10000036141	2	Foam, rain shield - large top	
26	60507	8	Screw, .312-18 x 1.0 standard hex, SS	
27	60701	8	Washer, .312 split lock, SS	
28	61069	6	Screw, .625-11 x 1.750 standard hex, G5	
29	60193	6	Washer, M16 flat	
30	66702	2	Light, clearance, no grommet, 2.0 in. - amber LED	
--	67856	1	Harness, trailer extension assembly - 100 in	
--	68281	1	Harness, trailer lights - LED	

FUEL TANK ASSEMBLY

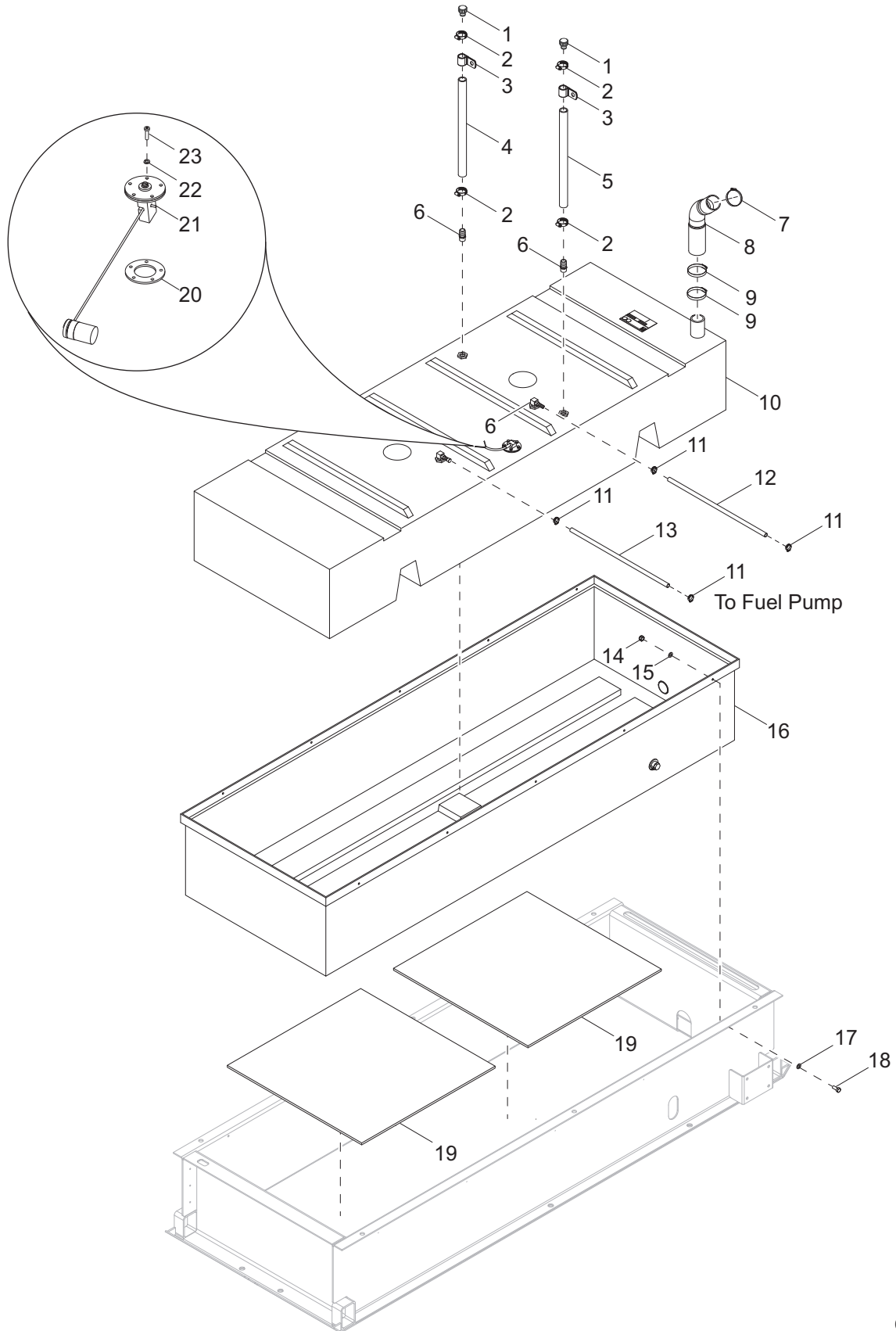

02668

FUEL TANK ASSEMBLY

Item	Part No.	Qty	Description	Notes
1	26379	2	Vent, plastic fuel - 1.0 ID	
2	19338	4	Clamp, hose - SAE 016 (.68-1.50)	
3	60716	2	Clamp, tubing - 1.50 light duty	
4	50019	3 ft	Hose, fuel - 1.0, SAE 20R3	
5	50019	3 ft	Hose, fuel - 1.0, SAE 20R3	
6	25496	2	Fitting, strt - .750MNPT x 1.0 barb, brass	
7	19336	1	Clamp, hose - SAE 044 (2.31-3.25)	
8	37630	1	Hose, fuel fill	
9	18663	2	Clamp, hose - SAE 060 (3.31-4.25)	
10	37052	1	Tank, fuel - 100 gal. poly	
11	19453	4	Clamp, hose - SAE 006 (.37-.87)	
12	50051	2 ft	Hose, fuel - .375 ID, 50 psi, SAE 30R7	
13	50051	2.33 ft	Hose, fuel - .375 ID, 50 psi, SAE 30R7	
14	60144	10	Nut, .250-20 nylock, G5	
15	60243	10	Washer, .250 flat .735/.060	
16	37053	1	Pan, 24 hr containment, poly	
17	60696	10	Washer, .250 flat .625/.050, SS	
18	60620	10	Screw, .250-20 x 1.0 standard hex, SS	
19	10000036134	2	Foam, neoprene, containment liner	
20	22323	1	Gasket, fuel sender	
21	36243	1	Fuel sender	
22	60252	5	Washer, #10 split lock	
23	60062	5	Screw, 10-32 c .750 pan Phillips, G2	
--	60479	2	Screw, .250-20 x 1.0 serrated flange hex, G5	To attach item 3
--	60161	2	Nut, .250-20 serrated flange, G5	To attach item 3

TRAILER ASSEMBLY - SINGLE AXLE

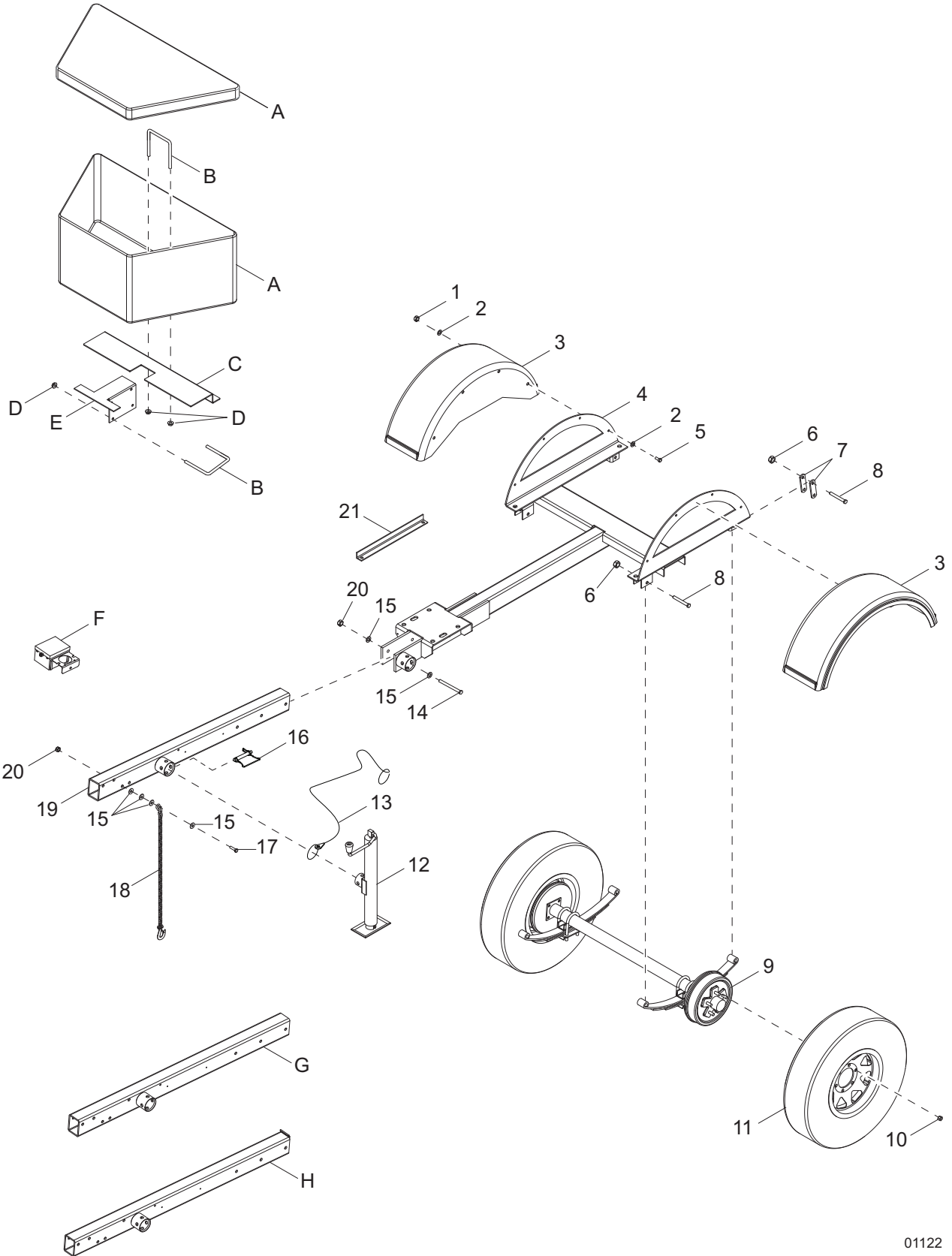

01122

TRAILER ASSEMBLY - SINGLE AXLE

Item	Part No.	Qty	Description	Notes
1	60358	8	Nut, .375-16 nylock, G5	
2	60698	16	Washer, .375 flat .875/.040, SS	
3	11381	2	Fender, plastic - single, 14 in. tire	
4	37092B	1	Weldment, trailer chassis	
5	61036	8	Screw, .375-16 x 1.25 standard hex, SS	
6	60504	6	Nut, .562-18 lock hex, G5	
7	19637	4	Plate, shackle bracket - 3.125 in	
8	60503	6	Screw, shackle - .562-18 x 3.0 standard hex, G5	
9	51098	1	Assembly, axle	
10	60096	10	Nut, .500-20 lug, G5	
11	30389B	2	Wheel, ST225/75R15, 2800 lb	
12	13051	1	Jack, top wind - 2000 lb, tube mounted	
13	12647	1	Cable, tether - jack pin and ground rod cover	
14	61104	3	Screw, .500-13 x 5.50 standard hex, G8	
15	60416	14	Washer, .500 flat 1.375/.090	
16	23256	1	Pin, jack - 2000 lb tube mounted	
17	60376	2	Screw, .500-13 x 4.50 standard hex, G5	
18	23367	2	Chain, safety - 7800 lbs rated	
19	24812B	1	Weldment, tongue - non-adjustable	
20	62221	5	Nut, .500-13 nylock, G5	
21	24691B	1	Brace, tongue shipping	
--	61103	1	Screw, .500-13 x 1.750 serrated flange hex, G8	To attach item 21
--	62221	1	Nut, .500-13 nylock, G5	To attach item 21
<i>Toolbox: (if equipped)</i>				
A	32214	1	Toolbox, trailer front - 49 x 15 x 18.5 (L x W x H) poly	
B	62021	2	Bolt, U - .375-16 x 4.0 x 4.625	
C	37693B	1	Bracket, toolbox mount	
D	60145	4	Nut, .375-16 serrated flange, G5	
E	37694B	1	Bracket, toolbox mount	
<i>Electric Brakes: (if equipped)</i>				
F	19417	1	Breakaway kit	
--	19438	1	Harness, wiring - electric brakes	
--	65899	1	Harness, electric brake	
<i>Adjustable Hitch Tongues: (if equipped)</i>				
G	30931B	1	Weldment, tongue w/support plate - electric brake	
H	35075B	1	Weldment, flip tongue - surge brake	

TRAILER ASSEMBLY - TANDEM AXLE

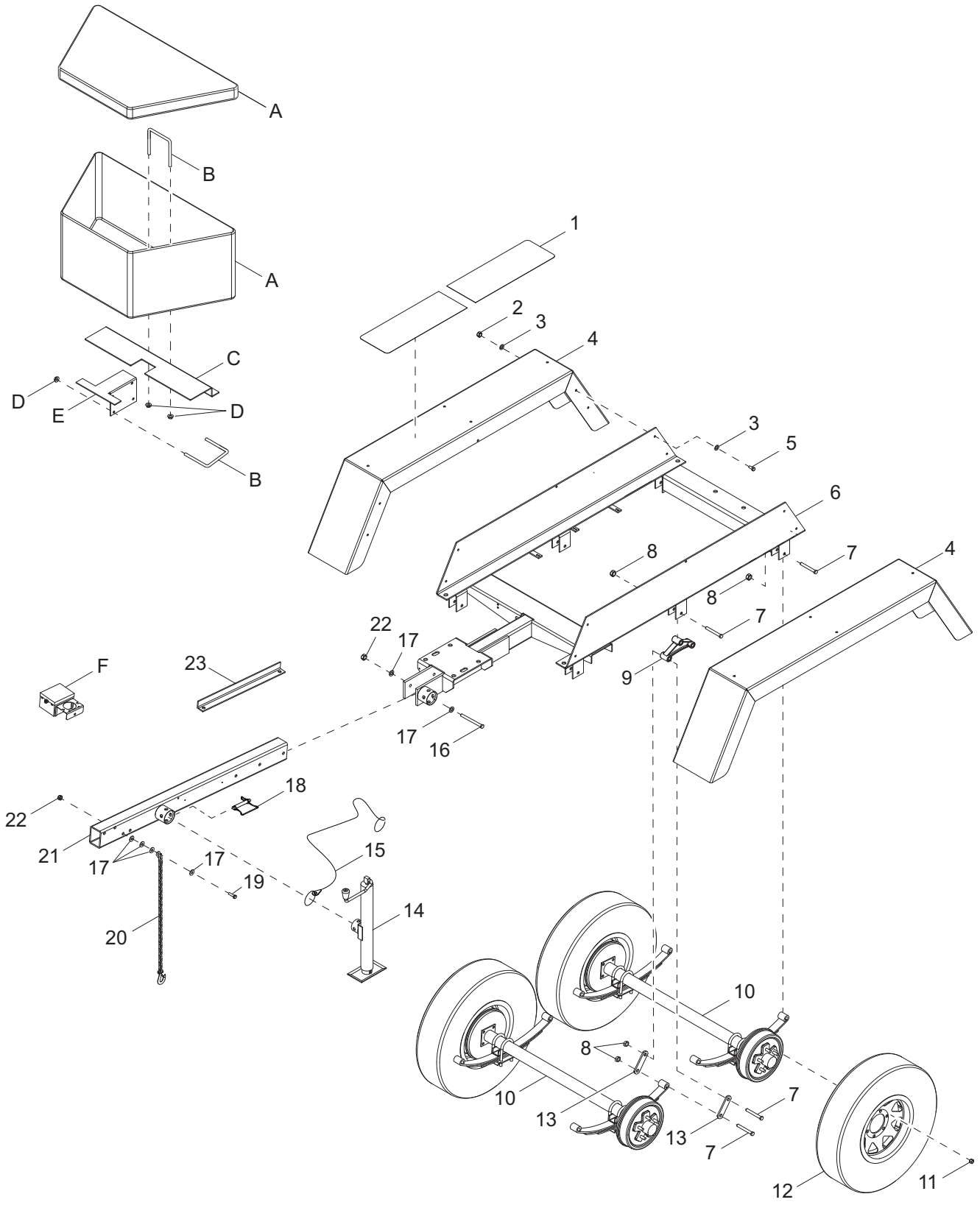

01214

TRAILER ASSEMBLY - TANDEM AXLE

Item	Part No.	Qty	Description	Notes
1	22398	4	Pad, slip resistant - 10.0 x 28.0	
2	60358	10	Nut, .375-16 nylock, G5	
3	60698	20	Washer, .375 flat .875/.040, SS	
4	22976B	2	Weldment, fender tandem	
5	61036	10	Screw, .375-16 x 1.25 standard hex, SS	
6	24789B	1	Weldment, flip tongue trailer - tandem	
7	60503	14	Screw, shackle, .562-18 x 3.0 standard hex, G5	
8	60504	14	Nut, .562-18 lock, G5	
9	40545	2	Equalizer, tandem axle - 5.625 centers	
10	19421	2	Assembly, axle	
11	60096	20	Nut, .500-20 lug, G5	
12	15540	4	Wheel, ST205/75R15, 1598 lb - 6 pr	
13	19637	8	Plate, shackle bracket - 3.125 in	
14	13051	1	Jack, top wind - 2000 lb, tube mounted	
15	12647	1	Cable, tether - jack pin and ground rod cover	
16	61104	3	Screw, .500-13 x 5.50 standard hex, G8	
17	60416	14	Washer, .500 flat 1.375/.090	
18	23256	1	Pin, jack - 2000 lb, tube mounted	
19	60376	2	Screw, .500-13 x 4.50 standard hex, G5	
20	23367	2	Chain, safety - 7800 lbs rated	
21	30931B	1	Weldment, tongue w/support plate	
22	62221	5	Nut, .500-13 nylock, G5	
23	24691B	1	Brace, tongue shipping	
--	61103	1	Screw, .500-13 x 1.750 serrated flange hex, G8	To attach item 25
--	62221	1	Nut, .500-13 nylock, G5	To attach item 25
<i>Toolbox: (if equipped)</i>				
A	32214	1	Toolbox, trailer front - 49 x 15 x 18.5 (L x W x H) poly	
B	62021	2	Bolt, U - .375-16 x 4.0 x 4.625	
C	37693B	1	Bracket, toolbox mount	
D	60145	4	Nut, .375-16 serrated flange, G5	
E	37694B	1	Bracket, toolbox mount	
<i>Electric Brakes: (if equipped)</i>				
F	19417	1	Breakaway kit	
--	65821	1	Harness, electric brake	

TRAILER BRAKE LINES - SINGLE AXLE

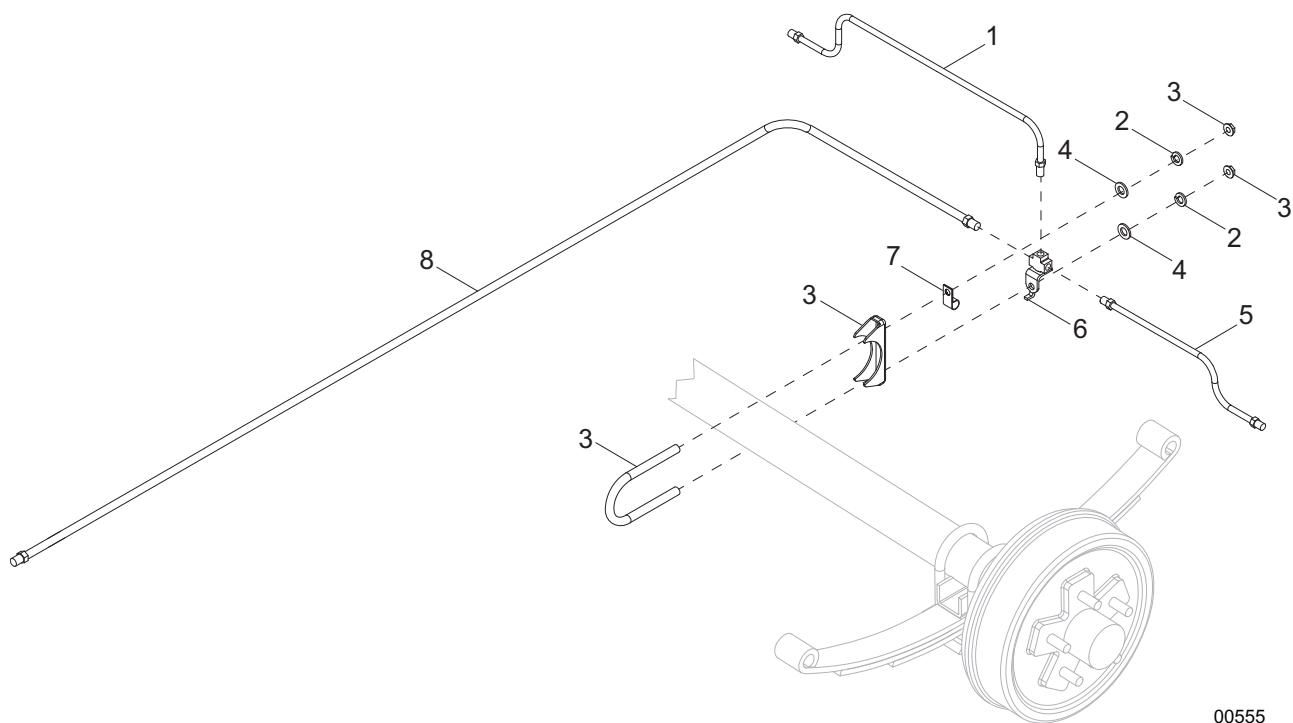

00555

TRAILER BRAKE LINES - SINGLE AXLE

Item	Part No.	Qty	Description	Notes
1	23169	1	Line, brake - .188 x 12.0	
2	60341	2	Washer, M8 split lock, SS	
3	61064	1	Clamp, muffler - 3.0 light duty	
4	60166	2	Washer, M8 flat	
5	40494	1	Line, brake - .188 x 30.0	
6	19252	1	Fitting, strt - .188 brake line T w/bracket, all female	
7	61010	1	Clamp, tubing - .375 heavy duty, .375 bolt	
8	24688	1	Hose, brake - .188 x 136.0, male/male	
--	60231	6	Rivet, .188 diameter x .375 to .500 grip	
--	15626	6	Clamp, tubing - .375 light duty	
--	22340	1	Fitting, bushing - 1.0 OD x .750 ID	

TRAILER BRAKE LINES - TANDEM AXLE

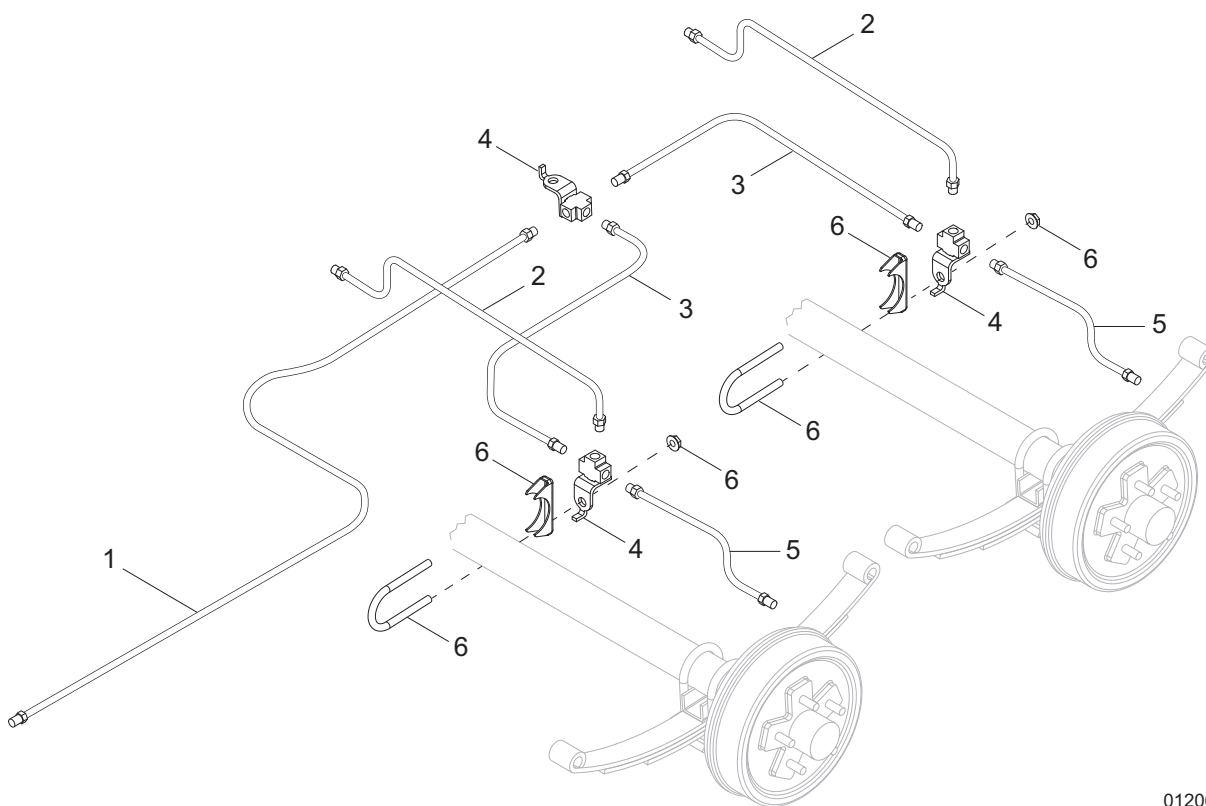

01206

TRAILER BRAKE LINES - TANDEM AXLE

Item	Part No.	Qty	Description	Notes
1	24688	1	Hose, brake - .188 x 136.0, male/male	
2	40495	2	Line, brake - .188 x 20.0	
3	40817	2	Hose, brake - .188 x 33.0, male/male	
4	19252	3	Fitting, strt - .188 brake line T w/bracket, all female	
5	40494	2	Line, brake - .188 x 30.0	
6	61028	2	Clamp, muffler - 2.50 light duty	
--	22340	4	Fitting, bushing - 1.0 OD x .750 ID	
--	15626	5	Clamp, tubing - .375 light duty	
--	60231	3	Rivet, .188 diameter x .375 to .500 grip	
--	60684	2	Screw, .250-20 x .875 standard hex, SS	
--	60166	2	Washer, M8 flat	
--	60144	2	Nut, .250-20 nylock, G5	

TRAILER HITCH OPTIONS

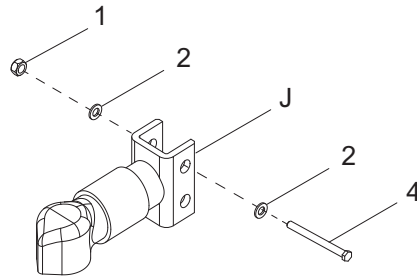
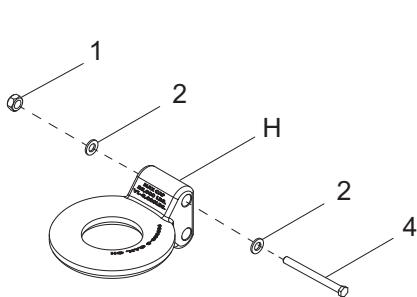
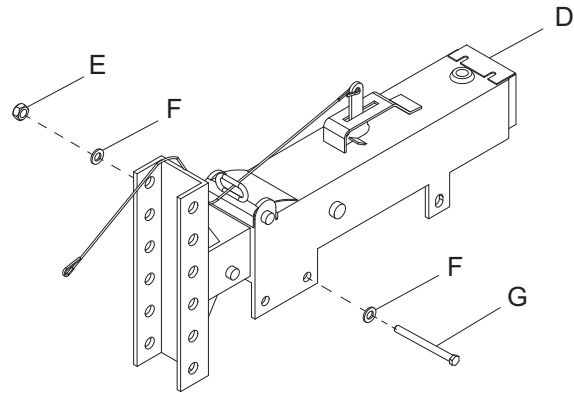
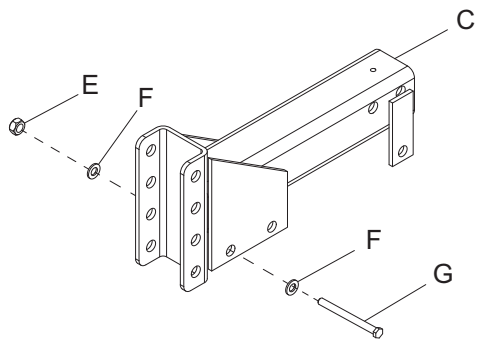
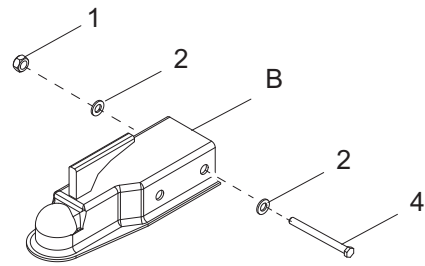
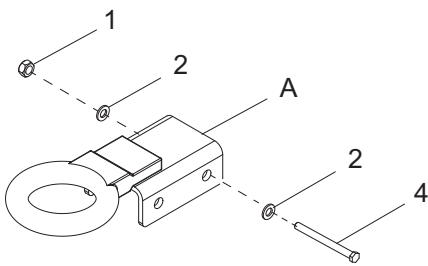
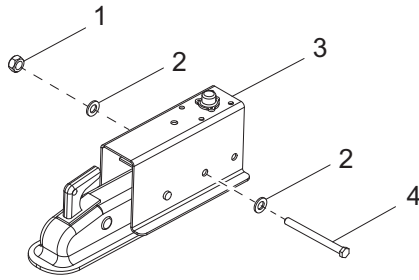

01123

TRAILER HITCH OPTIONS

Item	Part No.	Qty	Description	Notes
1	62221	2	Nut, .500-13 nylock, G5	
2	60309	4	Washer, .500 flat 1.060/.090	
3	40529	1	Actuator, hydraulic surge brake - 2 in. ball, 6000 lb	
4	61099	2	Screw, .500-13 x 5.0 standard hex, G8	
--	41762	1	O-ring - 24 mm	
<i>Non-Adjustable Electric Brake Hitches: (if equipped)</i>				
A	11032B	1	Weldment, Lunette ring - 3.0 ID	
B	23162	1	Coupler, 2.0 ball/3.0 channel - 5000 lb	
<i>Adjustable Hitches: (if equipped)</i>				
C	19379B	1	Weldment, hitch - 4 position, electric brake	
D	40529	1	Actuator, hydraulic surge brake - 7500 lb, surge brake	
E	62221	3	Nut, .500-13 nylock, G5	
F	60309	6	Washer, .500 flat 1.060/.090	
G	61099	3	Screw, .500-13 x 5.0 standard hex, G8	
H	19335B	1	Coupler, Lunette ring - 3.0 ID	Requires item C or D
J	19518	1	Coupler, 2.0 ball	Requires item C or D
<i>Adapters - Electric Brake: (if equipped)</i>				
--	65593	1	Adapter, trailer - 4 pin and 2 pin to 6 pin	
--	65583	1	Adapter, trailer - round 6 pin to round 7 spade	Requires 65593
<i>Adapters - Surge Brake: (if equipped)</i>				
--	65463	1	Adapter, trailer - flat 4 pin to round 6 pin	
--	65464	1	Adapter, trailer - flat 4 pin to round 7 pin	
--	65465	1	Adapter, trailer - flat 4 pin to round 7 spade	

RECOMMENDED SPARE PARTS - ENGINE AND SERVICE KITS

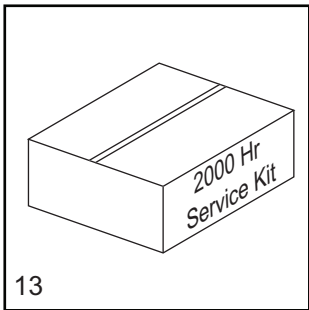
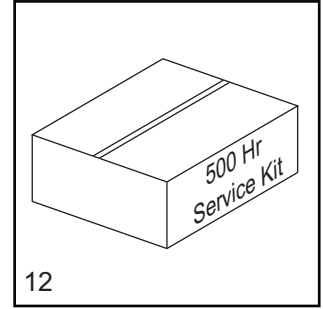
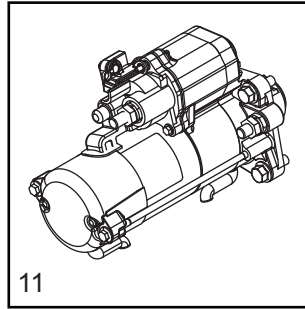
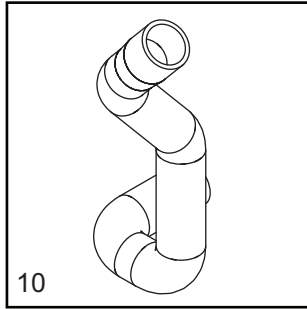
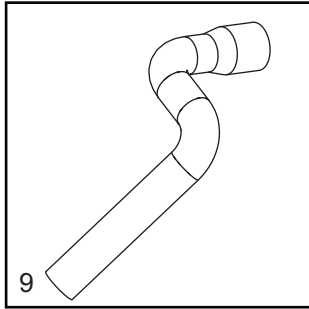
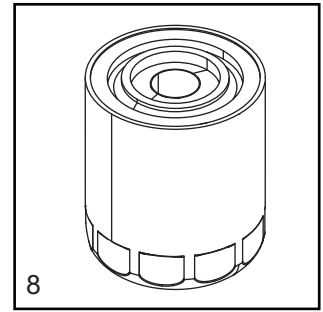
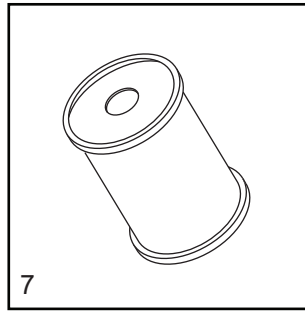
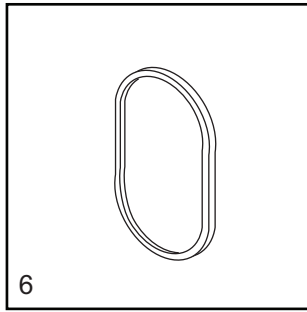
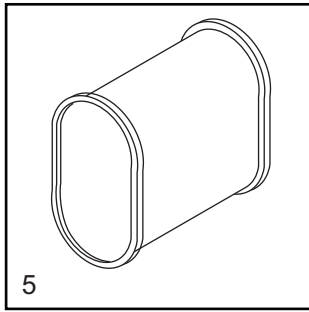
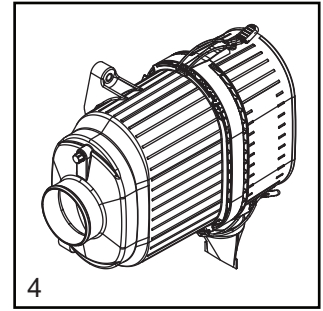
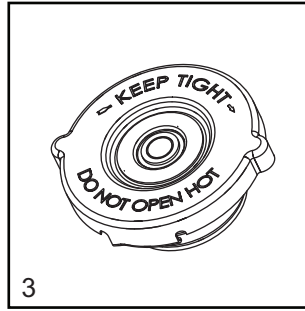
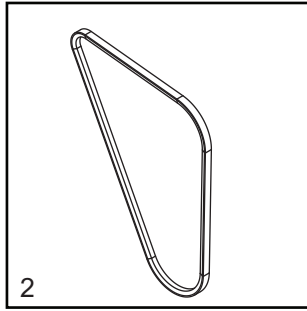
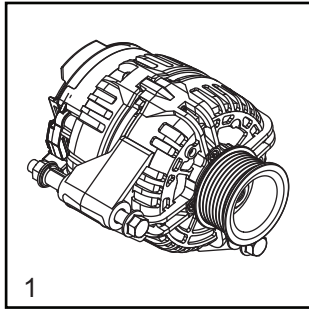

RECOMMENDED SPARE PARTS - ENGINE AND SERVICE KITS

ENGINE

1. Alternator	51205
2. Belt, fan	51201
3. Cap, radiator.....	19219
4. Filter, air - housing assembly.....	52736
5. Filter, air - primary element.....	68894
6. Filter, air - secondary element	68895
7. Filter, fuel - primary.....	51202
8. Filter, oil	29487
9. Hose, radiator - lower	52667
10. Hose, radiator - upper.....	52666
11. Starter	51203

SERVICE KITS

12. 500 hour kit.....	10000035993
-----------------------	-------------

Includes: Air Filter-primary 68894, Air Filter-secondary 68895, Fuel Filter 51202, Engine Belt 51201, and Oil Filter 29487

13. 2000 hour kit.....	SK327
------------------------	-------

Includes: Air Filter-primary 68894 (4), Air Filter-secondary 68895 (4), Fuel Filter 51202 (8), Engine Belt 51201 (2), and Oil Filter 29487 (8)

RECOMMENDED SPARE PARTS - ELECTRICAL AND TRAILER

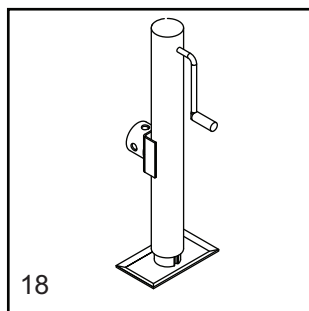
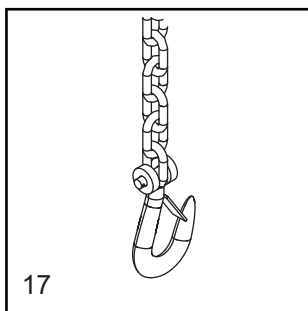
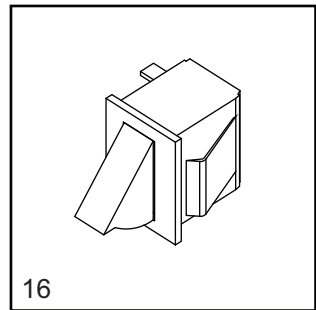
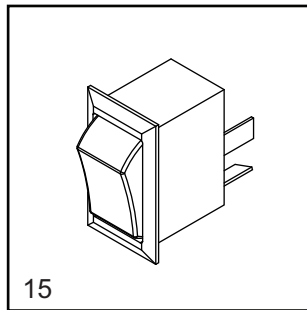
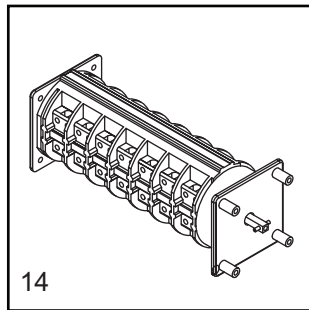
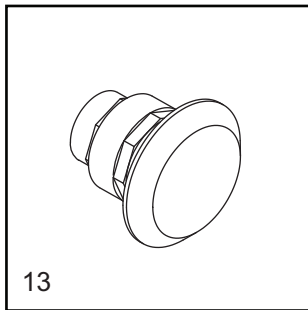
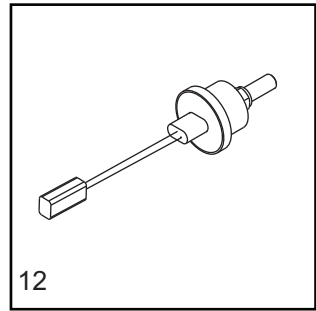
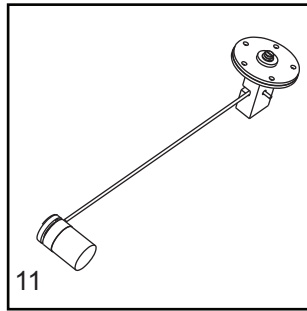
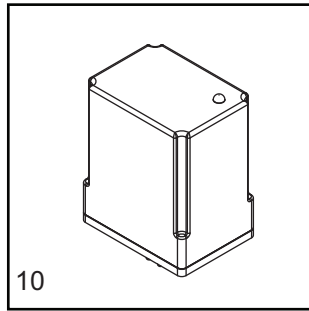
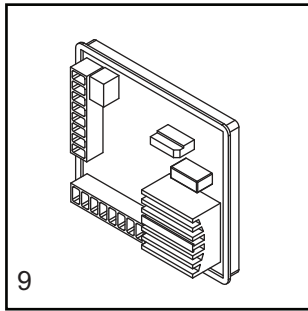
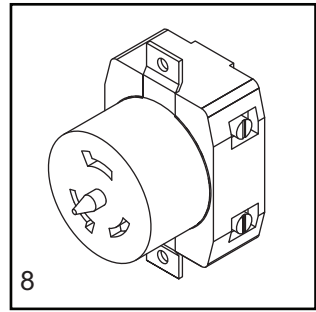
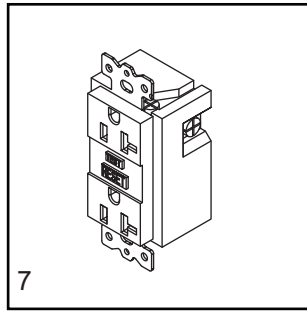
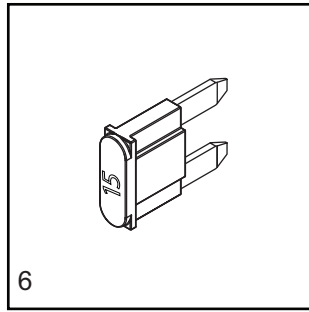
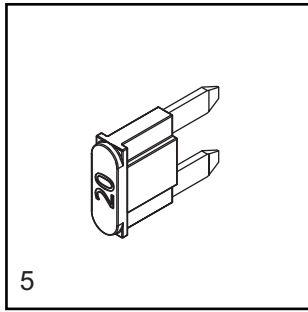
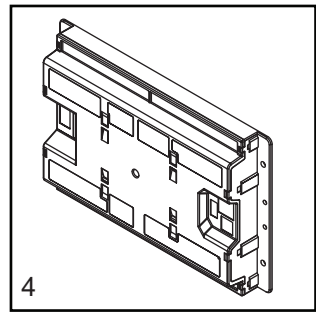
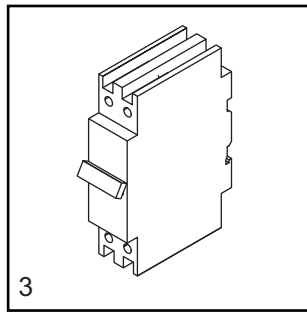
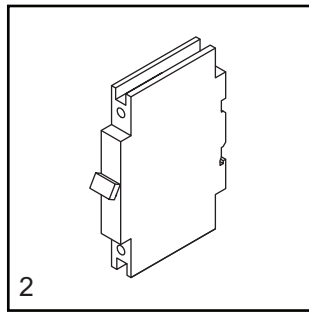
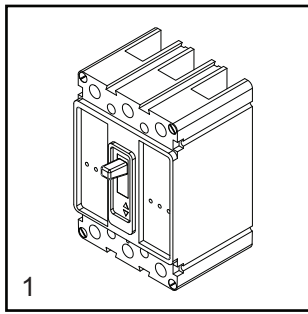

02524

RECOMMENDED SPARE PARTS - ELECTRICAL AND TRAILER

ELECTRICAL

1. Breaker, main	65452
2. Breaker, 20A	18091
3. Breaker 50A	18092
4. Controller, programmed	68926
5. Fuse, 20 A	35560
6. Fuse, 15A	68204
7. Receptacle, 120V/20A GFI	14130
8. Receptacle, 240V/50A twist lock	18089
9. Regulator, voltage	68015
10. Relay (Optional)	66455
11. Sender, fuel	36243
12. Sensor, low coolant	68206
13. Switch, E-stop assembly	34989SRV
14. Switch, phase - 3 position	37193
15. Switch, rocker	66995
16. Switch, trigger safety	66089

TRAILER

17. Chain, safety	23367
18. Jack, 2000 lb top wind	13051

Note: To order replacement controller, contact Generac Mobile Products with unit serial number

Part No. 51200 Rev. B 10/31/2018

©2018 Generac Mobile Products, LLC
All rights reserved.

Specifications are subject to change without notice.
No reproduction allowed in any form without prior written consent
from Generac Mobile Products, LLC.

GENERAC | **MOBILE**

Generac Mobile Products, LLC
215 Power Drive, Berlin, WI 54923
GeneracMobileProducts.com | 800-926-9768 | 920-361-4442